

W IE3 Premium efficiency motors
Aluminium and Cast Iron frame



Frame 80 to 355



F.S.E. Tamel S.A.

33-100 Tarnow.

ul. Elektryczna 6, Poland

phone: +48 14 632 11 00

fax: +48 14 621 96 64

E-mail: officetamel@tamel.pl

Internet: www.tamel.pl

**BROOK
CROMPTON**

Every care has been taken to ensure the accuracy of the information contained in this publication, but, due to a policy of continuous development and improvement the right is reserved to supply products which may differ slightly from those illustrated and described in this publication

Table of contents

Introduction	4
Specification, standards and regulations	5
Performance data - aluminium frame:	
2 pole.....	6
4 pole.....	7
6 pole.....	8
Performance data - cast iron frame:	
2 pole.....	9
4 pole.....	11
6 pole.....	13
Dimensions - aluminium frame:	
Shaft, flange, face tolerance details and notes.....	15
Foot (B3) / Flange (B5) / Face mounting (B14) - TEFV.....	16
Pad/rod mounting (B30) - AOM.....	18
Dimensions - cast iron frame:	
Shaft, flange, face tolerance details and notes.....	19
Foot (B3) / Flange (B5) / Face mounting (B14) - TEFV 80 - 180.....	20
Foot (B3) / Flange (B5) - TEFV frames 200 - 355 European specification.....	22
Foot (B3) / Flange (B5) - TEFV frames 200 - 355 BS specification.....	24
Mounting option	26
Technical information - aluminium frame:	
Bearing and grease arrangement.....	27
Approximate shipping specifications.....	27
Axial and radial loads.....	28
Technical information - cast iron frame:	
Bearing references and oil seals.....	29
Grease life time.....	29
Approximate shipping specifications.....	30
Axial and radial loads frames 80 - 180.....	30
Axial and radial loads frames 200 - 355.....	31
Electrical	32
Useful information	33
Notes	34
Worldwide sales and service network	36

Introduction

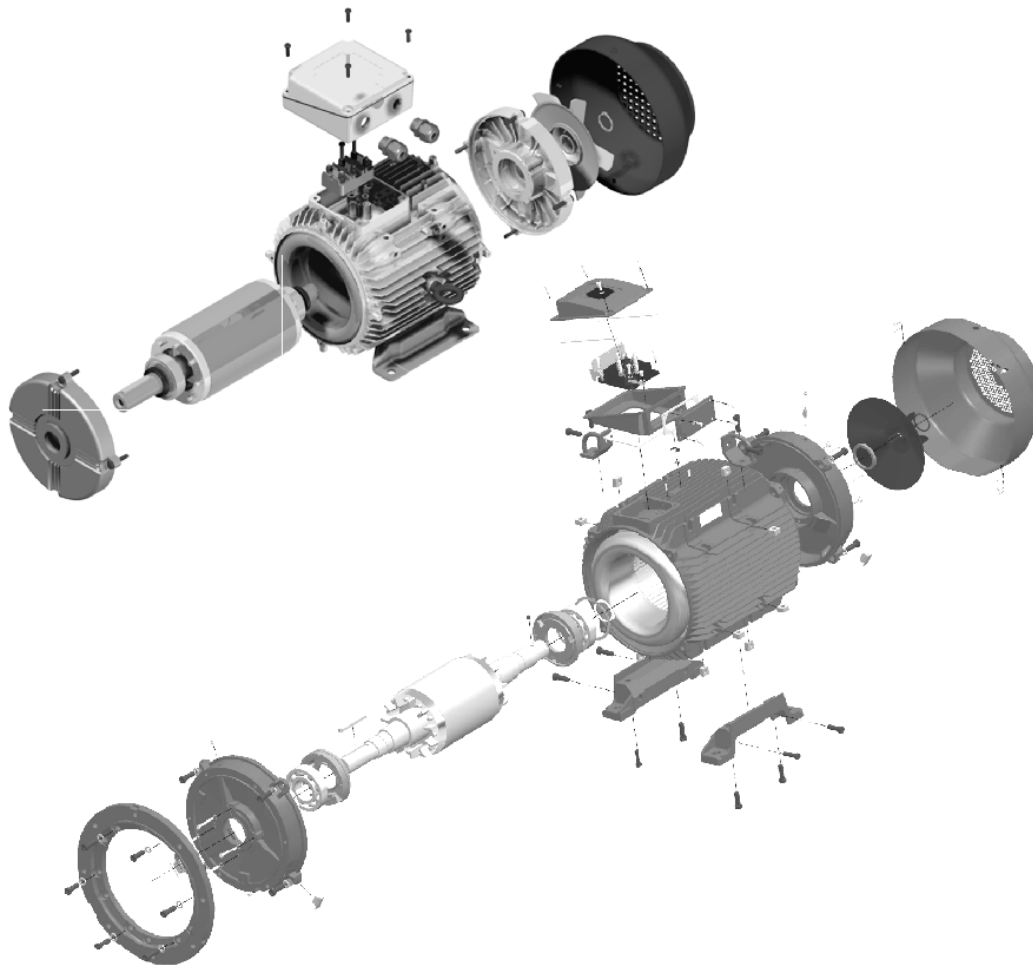

Brook Crompton a company of ATB group

Brook Crompton is a leading manufacturer of electric motors for the global industrial market, with motor solutions which benefit a wide range of customers.

Throughout the branch, new ATB developments and systems solutions are regarded as intelligent. This means that they are efficient, individually manufactured, extremely economic and underpinned by close co-operation with customers. Many years of experience and the know-how of the work force have been merged and play a fundamental role in product intelligence. In addition, the Group also provides on-site system integration, in order to guarantee customers optimum advantages from ATB solutions.

ATB also demonstrates flexibility in the production area.

Quality assurance

ATB is a name for quality production. For standards that are maintained by means of continuous investment in modern production systems such as resin impregnation plants, CNC processing centres, assembly robots and winding centres.

Efficiency is further raised by on-going improvements to the material flow and layout design.

Stringent quality procedures are observed from first design to finished product in accordance with the ISO9001:2008 documented quality systems.

Our factories have been assessed to meet these requirements, a further assurance that only the highest possible standards of quality are accepted.



Specification, standards and regulations

New legal regulations

In connection with the international discussion on energy efficiency, a world-wide harmonized energy efficiency classification system has been established for low-voltage three-phase asynchronous motors.

New international efficiency classes of motors: (IE = international Efficiency)

The new IEC60034-30:2009 defines world-wide the following efficiency classes in the power range from 0,75kW to 375kW 2p, 4p and 6p motors.

- IE1 – Standard Efficiency (equivalent of EFF2)
- IE2 – High Efficiency (equivalent of EFF1)
- IE3 – Premium Efficiency
- IE4 – Super Premium Efficiency

The efficiency factor defines the efficiency of motors when transforming electrical into mechanical energy. The higher the energy efficiency class, the more complex the production of motors becomes and the more material e.g. Copper, has to be used, which results in correspondingly higher prices. However, in relation to the economic life-time, the price impact by only a few percent and the additional cost will be amortized by the savings in energy costs in a short time.

A new method for determining efficiency

From now on, motors can be offered and sold with the new classes IE1, IE2 and IE3. In that case, the efficiency has to be determined according to the new measuring standard EN60034-2-1:2007.

The new method leads to substantially increased accuracy under exactly defined laboratory condition. When comparing the measurements of the same motor, it is expected that the energy efficiency level measured with the new method will be a few percentage points less than the efficiency levels defined by the old method.

There are a few different method of determining the efficiency with low medium and high uncertainty. For IE1 (standard efficiency) and motors below standard efficiency, test associated with low and medium uncertainty are acceptable. For higher efficiency levels only methods associated with low uncertainty shall be acceptable.

The methods for determining the efficiency are based on number of assumptions and it is not possible to make a comparison between the values of efficiency obtained by different methods. Therefore the motor documentation must state which method was used.

Under the new standard Brook Crompton uses indirect calculation method, additional load losses determined from measuring.

Climate protection

Today's energy trends and drivers:

- EU targets for increased energy efficiency:
 - 20% CO₂ emission
 - +20% energy efficiency
 - 20% the proportion of renewable energy
- Increased industrial efficiency through process optimization
- Limited availability of primary energy resources such as oil, gas, coal
- Higher financial cost of energy resources such as oil, gas, coal
- Globalization in the context of energy and the environment

The Brook Crompton high efficiency motor design has been optimized for application like compressors, pumps, cranes, lifts, fans and gearboxes. In these sectors customers can find the biggest potential for energy and cost savings.

Motor System Energy by Application

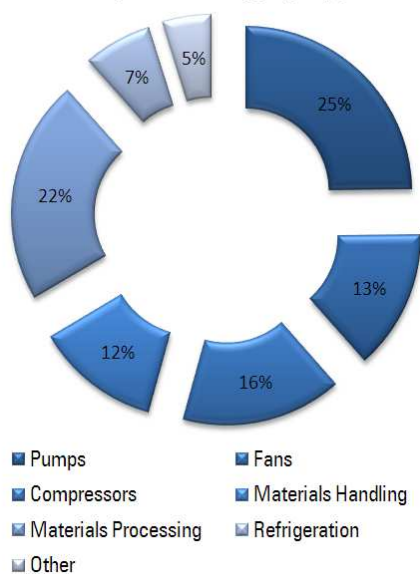

Specification

Enclosure

All motors are totally enclosed with a minimum ingress protection of IP55 as defined in IEC 60034-5 (BS EN 60034 part 5). Higher IP protection can be supplied for special request.

Motor cooling

Motors are cooled in accordance with EN 60034-6. The normal arrangement is IC411 (Totally Enclosed Fan Ventilated) via a fan mounted at the non-drive end. Alternative methods of cooling available on request.

Insulation and thermal rating

Standard motors will operate satisfactorily in an ambient temperature range of -30°C to +40°C (Class B temperature rise) and altitudes up to 1000 metres above sea level.

Duty cycle

All standard WU-DA motors are suitable for SI Duty as described in IEC 60034-1.

Electrical characteristics

All 'W' motors are wound for the 'Eurovoltage'. Motors up to and including 3kW are normally supplied 230/400V, 4kW and above supplied 400V and are suitable for ±10% tolerance in line with IEC60034-1 standard..

Standard compliance

Brook Crompton motors are of the totally enclosed, single or three phase squirrel cage type, built to comply with international IEC and EN standards. Motors conforming to other national and international specifications are also available on request.

Electrical	Mechanical
IEC/EN 60034-1	IEC 60072
IEC/EN 60034-2-1	IEC/EN 60034-5
IEC/EN 60034-30	IEC/EN 60034-6
IEC 60034-8	IEC/EN 60034-7
IEC 60034-12	IEC/EN 60034-9
	IEC 60034-14

Performance data - aluminium frame

3000 min⁻¹ (2 pole)

Rated power P_N Kw (HP)	Full load speed in revolutions per minute n min ⁻¹	Frame reference and size Type	Full load current at rated voltage I_N 400V A	Efficiency η 1.0P _N 0.75P _N 0.5P _N	Power factor $\cos \phi$ 1.0P _N 0.75P _N 0.5P _N	Power factor	Full load torque M_N Nm	Direct on line starting torque ratio $\frac{M_A}{M_N}$	Direct on line starting current ratio $\frac{I_A}{I_N}$	Direct on line pull out torque ratio $\frac{M_K}{M_N}$	Direct on line pull up torque ratio $\frac{M_S}{M_N}$	Rotor inertia WJ ² J kgm ²	Sound pressure level @ 1m on no load L _{PA} dB(A)	Weight kg
0.75 (1.0)	2890	WP-DA80MM IE3	1.55	$\left. \begin{array}{l} 80.7 \\ 81.0 \\ 77.0 \end{array} \right\}$	$\left. \begin{array}{l} 0.86 \\ 0.80 \\ 0.68 \end{array} \right\}$		2.5	3.3	7.7	3.1	2.5	0.0013	56	9.5
1.1 (1.5)	2885	WP-DA80MS IE3	2.30	$\left. \begin{array}{l} 83.5 \\ 84.8 \\ 83.5 \end{array} \right\}$	$\left. \begin{array}{l} 0.84 \\ 0.78 \\ 0.66 \end{array} \right\}$		3.6	3.5	7.7	3.1	2.8	0.0012	56	
1.5 (2.0)	2880	WP-DA90SMX IE3	3.00	$\left. \begin{array}{l} 84.2 \\ 84.5 \\ 82.0 \end{array} \right\}$	$\left. \begin{array}{l} 0.86 \\ 0.81 \\ 0.70 \end{array} \right\}$		5.0	3.4	8.2	3.6	3.2	0.0014	66	16.5
2.2 (3.0)	2895	WP-DA90LSX IE3	4.60	$\left. \begin{array}{l} 85.9 \\ 85.9 \\ 84.2 \end{array} \right\}$	$\left. \begin{array}{l} 0.81 \\ 0.73 \\ 0.59 \end{array} \right\}$		7.3	3.8	8.5	4.1	3.6	0.0016	66	18.0
3.0 (4.0)	2880	WP-DA100LMF IE3	5.30	$\left. \begin{array}{l} 87.1 \\ 88.7 \\ 88.7 \end{array} \right\}$	$\left. \begin{array}{l} 0.93 \\ 0.90 \\ 0.84 \end{array} \right\}$		10.0	3.0	8.2	3.3	2.8			
4.0 (5.5)	2895	WP-DA112MR IE3	7.30	$\left. \begin{array}{l} 88.5 \\ 89.2 \\ 88.5 \end{array} \right\}$	$\left. \begin{array}{l} 0.90 \\ 0.85 \\ 0.74 \end{array} \right\}$		13.2	3.9	10	4.8	3.8	0.0064	60	
5.5 (7.5)	2930	WP-DA132SGX IE3	10.6	$\left. \begin{array}{l} 90.5 \\ 90.5 \\ 88.8 \end{array} \right\}$	$\left. \begin{array}{l} 0.83 \\ 0.76 \\ 0.63 \end{array} \right\}$		17.9	3.9	10	4.8	3.6	0.015	66	
7.5 (10)	2930	WP-DA132SMX IE3	13.7	$\left. \begin{array}{l} 91.0 \\ 91.2 \\ 90.3 \end{array} \right\}$	$\left. \begin{array}{l} 0.87 \\ 0.81 \\ 0.70 \end{array} \right\}$		24.4	3.6	9.6	4.3	3.3	0.018	66	
11 (15)	2945	WP-DA160MJ IE3	19.6	$\left. \begin{array}{l} 92.2 \\ 92.5 \\ 91.5 \end{array} \right\}$	$\left. \begin{array}{l} 0.88 \\ 0.85 \\ 0.77 \end{array} \right\}$		35.7	2.4	8.5	3.6	1.8	0.045	68	73.0
15 (20)	2940	WP-DA160LR IE3	26.0	$\left. \begin{array}{l} 93.0 \\ 93.3 \\ 93.1 \end{array} \right\}$	$\left. \begin{array}{l} 0.90 \\ 0.87 \\ 0.79 \end{array} \right\}$		48.7	2.2	8.6	3.7	1.9	0.056	68	80.0
18.5 (25)	2955	WP-DA160LT IE3	32.5	$\left. \begin{array}{l} 93.3 \\ 93.4 \\ 92.5 \end{array} \right\}$	$\left. \begin{array}{l} 0.88 \\ 0.84 \\ 0.75 \end{array} \right\}$		59.8	2.7	9.0	4.0	2.2	0.063	68	
22 (30)	2950	WP-DA180MF IE3	38.1	$\left. \begin{array}{l} 93.6 \\ 93.6 \\ 93.1 \end{array} \right\}$	$\left. \begin{array}{l} 0.89 \\ 0.85 \\ 0.77 \end{array} \right\}$		71.2	2.4	9.5	4.0	2.1	0.089	68	

Performance data - aluminium frame

1500 min⁻¹ (4 pole)

Rated power	Full load speed in revolutions per minute	Frame reference and size	Full load current at rated voltage	Efficiency	Power factor	Full load torque	Direct on line starting torque ratio	Direct on line starting current ratio	Direct on line pull out torque ratio	Direct on line pull up torque ratio	Rotor inertia Wk ²	Sound pressure level @ 1m on no load	Weight
P _N Kw (HP)	n min ⁻¹	Type	I _N 400V A	η 1.0P _N 0.75P _N 0.5P _N	Cos φ 1.0P _N 0.75P _N 0.5P _N	M _N Nm	$\frac{M_A}{M_N}$	$\frac{I_A}{I_N}$	$\frac{M_K}{M_N}$	$\frac{M_S}{M_N}$	J kgm ²	L _{PA} dB(A)	kg
1.1 (1.5)	1430	WP-DA90STX IE3	2.50	84.1 84.4 84.0	0.77 0.70 0.57	7.3	3.0	7.0	3.5	2.7	0.0037	48	
1.5 (2.0)	1440	WP-DA90LWX IE3	3.60	85.3 85.3 83.2	0.70 0.58 0.46	9.9	4.2	7.4	4.7	4.1	0.0042	48	20.5
2.2 (3.0)	1450	WP-DA100LRF IE3	4.60	86.7 87.0 86.0	0.79 0.70 0.57	14.5	3.3	7.3	3.3	3.0			
3.0 (4.0)	1460	WP-DA100LTF IE3	6.7	87.7 87.7 85.8	0.74 0.63 0.50	19.6	3.7	8.1	3.8	3.2			
4.0 (5.5)	1450	WP-DA112MWX IE3	8.4	88.6 88.6 88.0	0.78 0.70 0.56	26.3	3.5	8.0	3.5	2.9			
5.5 (7.5)	1460	WP-DA132STX IE3	10.9	89.6 90.0 88.7	0.81 0.73 0.60	36.0	3.3	8.7	3.9	2.7	0.030	59	57.0
7.5 (10)	1450	WP-DA132MVX IE3	14.6	90.4 91.3 90.4	0.82 0.73 0.60	49.4	3.2	7.6	3.4	2.6	0.033	59	60.5
11 (15)	1475	WP-DA160MR IE3	20.9	92.5 92.8 92.0	0.82 0.75 0.62	71.2	3.0	9.0	3.7	2.4	0.084	63	
15 (20)	1475	WP-DA160LU IE3	28.1	92.8 93.0 92.3	0.83 0.76 0.62	97.1	3.2	9.1	3.5	2.4	0.098	63	
18.5 (25)	1475	WP-DA180ME IE3	34.7	92.6 92.8 92.0	0.83 0.74 0.60	120	2.4	8.4	3.0	2.0	0.16	62	112.0
22 (30)	1470	WP-DA180LM IE3	41.1	93.0 93.0 93.0	0.83 0.75 0.62	143	2.4	8.8	3.0	2.0	0.17		

Performance data - aluminium frame

1000 min⁻¹ (6 pole)

Rated power	Full load speed in revolutions per minute	Frame reference and size	Full load current at rated voltage	Efficiency	Power factor	Full load torque	Direct on line starting torque ratio	Direct on line starting current ratio	Direct on line pull out torque ratio	Direct on line pull up torque ratio	Rotor inertia Wk ²	Sound pressure level @ 1m on no load	Weight
P _N Kw (HP)	n min ⁻¹	Type	I _N 400V A	η 1.0P _N 0.75P _N 0.5P _N	Cos φ 1.0P _N 0.75P _N 0.5P _N	M _N Nm	$\frac{M_A}{M_N}$	$\frac{I_A}{I_N}$	$\frac{M_K}{M_N}$	$\frac{M_S}{M_N}$	J kgm ²	L _{PA} dB (A)	kg
1.5 (2.0)	960	WP-DA100LRF IE3	4.4	82.5 82.1 78.9	0.60 0.51 0.40	14.9	3.5	6.2	4.1	3.6			
2.2 (3.0)	960	WP-DA112MWX IE3	5.8	84.3 84.4 81.8	0.65 0.58 0.43	21.9	2.8	5.6	3.0	2.4			
3.0 (4.0)	970	W-DA132MMX IE3	7.2	87.0 87.0 83.0	0.69 0.62 0.43	29.5	2.3	6.1	2.5	2.2	0.031		
4.0 (5.5)	960	W-DA132STX IE3	9.8	86.8 86.5 83.3	0.68 0.59 0.49	39.8	2.3	5.5	2.5	2.1	0.038		
5.5 (7.5)	965	W-DA 132MVX IE3	13.3	88.0 87 84	0.68 0.53 0.42	54.4	2.6	6.5	3.0	1.9			
7.5 (10)	975	W-DA160MM IE3	16.6	90.0 90.3 89.8	0.73 0.65 0.56	73.5	1.7	5.1	1.6	1.3	0.10		
11 (15)	980	W-DA 160LV IE3	22.4	90.3 90.3 90.0	0.75 0.69 0.59	107.2	2.0	7.5	2.5	1.9	0.12		
15 (20)	980	W-DA 180LR IE3	30.4	91.2 91.5 90.5	0.78 0.72 0.61	146.2	2.0	6.0	2.4	1.5			

Performance data - cast iron frame

3000 min⁻¹ (2 pole)

Rated power	Full load speed in revolutions per minute	Frame reference and size	Full load current at rated voltage	Efficiency	Power factor	Full load torque	Direct on line starting torque ratio	Direct on line starting current ratio	Direct on line pull out torque ratio	Direct on line pull up torque ratio	Rotor inertia Wk ²	Sound pressure level @ 1 m on no load	Weight
P _N Kw (HP)	n min ⁻¹	Type	I _N 400V A	η 1.0P _N 0.75P _N 0.5P _N	Cos φ 1.0P _N 0.75P _N 0.5P _N	M _N Nm	$\frac{M_A}{M_N}$	$\frac{I_A}{I_N}$	$\frac{M_K}{M_N}$	$\frac{M_S}{M_N}$	J kgm ²	L _{PA} dB(A)	kg
0.75 (1.0)	2890	WP-DF80MM IE3	1.55	$\left. \begin{array}{l} 80.7 \\ 81.0 \\ 77.0 \end{array} \right\}$	$\left. \begin{array}{l} 0.86 \\ 0.80 \\ 0.68 \end{array} \right\}$	2.5	3.3	7.7	3.1	2.5	0.0013	56	15
1.1 (1.5)	2885	WP-DF80MS IE3	2.30	$\left. \begin{array}{l} 83.5 \\ 84.8 \\ 83.5 \end{array} \right\}$	$\left. \begin{array}{l} 0.84 \\ 0.78 \\ 0.66 \end{array} \right\}$	3.6	3.5	7.7	3.1	2.8		56	
1.5 (2.0)	2880	WP-DF90LMX IE3	3.00	$\left. \begin{array}{l} 84.2 \\ 84.5 \\ 82.0 \end{array} \right\}$	$\left. \begin{array}{l} 0.86 \\ 0.81 \\ 0.70 \end{array} \right\}$	5.0	3.4	8.2	3.6	2.8	0.0014	66	30.5
2.2 (3.0)	2895	WP-DF90LSX IE3	4.60	$\left. \begin{array}{l} 85.9 \\ 85.9 \\ 84.2 \end{array} \right\}$	$\left. \begin{array}{l} 0.81 \\ 0.73 \\ 0.59 \end{array} \right\}$	7.3	3.8	8.5	4.1	3.6	0.0016	66	35
3.0 (4.0)	2880	WP-DF100LMF IE3	5.30	$\left. \begin{array}{l} 87.1 \\ 88.7 \\ 88.7 \end{array} \right\}$	$\left. \begin{array}{l} 0.90 \\ 0.90 \\ 0.84 \end{array} \right\}$	10	3.0	8.2	3.3	2.8		60	
4.0 (5.5)	2895	WP-DF112MR IE3	7.30	$\left. \begin{array}{l} 88.5 \\ 89.2 \\ 88.5 \end{array} \right\}$	$\left. \begin{array}{l} 0.90 \\ 0.85 \\ 0.74 \end{array} \right\}$	13.2	3.9	10	4.8	3.8	0.0064	60	
5.5 (7.5)	2930	WP-DF132SG IE3	10.6	$\left. \begin{array}{l} 90.5 \\ 90.5 \\ 88.8 \end{array} \right\}$	$\left. \begin{array}{l} 0.83 \\ 0.76 \\ 0.63 \end{array} \right\}$	17.9	3.9	10	4.8	3.6	0.015	66	
7.5 (10)	2930	WP-DF132SMX IE3	13.7	$\left. \begin{array}{l} 91.0 \\ 91.2 \\ 90.3 \end{array} \right\}$	$\left. \begin{array}{l} 0.87 \\ 0.81 \\ 0.70 \end{array} \right\}$	24.4	3.6	9.6	4.3	3.3	0.018	66	
11 (15)	2945	WP-DF160MJ IE3	19.6	$\left. \begin{array}{l} 92.2 \\ 92.5 \\ 91.5 \end{array} \right\}$	$\left. \begin{array}{l} 0.88 \\ 0.85 \\ 0.77 \end{array} \right\}$	35.7	2.4	8.5	3.6	1.8	0.045	68	120
15 (20)	2940	WP-DF160LR IE3	26.0	$\left. \begin{array}{l} 93.0 \\ 93.3 \\ 93.1 \end{array} \right\}$	$\left. \begin{array}{l} 0.90 \\ 0.87 \\ 0.79 \end{array} \right\}$	48.7	2.2	8.6	3.7	1.9	0.056	68	121
18.5 (25)	2955	WP-DF160LT IE3	32.5	$\left. \begin{array}{l} 93.3 \\ 93.4 \\ 92.5 \end{array} \right\}$	$\left. \begin{array}{l} 0.88 \\ 0.84 \\ 0.75 \end{array} \right\}$	59.8	2.7	9.0	4.0	2.2	0.063	68	
22 (30)	2950	WP-DF180MF IE3	38.1	$\left. \begin{array}{l} 93.6 \\ 93.6 \\ 93.1 \end{array} \right\}$	$\left. \begin{array}{l} 0.89 \\ 0.85 \\ 0.77 \end{array} \right\}$	71.2	2.4	9.5	4.0	2.1	0.089	68	
30 (40)	2950	WP-UDF200LNX IE3	53.0	$\left. \begin{array}{l} 93.3 \\ 93.3 \\ 93.0 \end{array} \right\}$	$\left. \begin{array}{l} 0.88 \\ 0.85 \\ 0.78 \end{array} \right\}$	97.1	2.8	9.0	3.0	2.4	0.15	73	255
37 (50)	2945	WP-UDF200LNX IE3	65.0	$\left. \begin{array}{l} 93.7 \\ 93.7 \\ 93.3 \end{array} \right\}$	$\left. \begin{array}{l} 0.88 \\ 0.85 \\ 0.78 \end{array} \right\}$	120	2.7	7.8	2.9	2.3	0.18	73	270
45 (60)	2960	WP-DF225MP IE3	77.0	$\left. \begin{array}{l} 94.3 \\ 94.3 \\ 93.3 \end{array} \right\}$	$\left. \begin{array}{l} 0.90 \\ 0.88 \\ 0.83 \end{array} \right\}$	145.2	2.3	7.8	2.8	1.9	0.38		

Performance data - cast iron frame

3000 min⁻¹ (2 pole)

Rated power	Full load speed in revolutions per minute	Frame reference and size	Full load current at rated voltage	Efficiency	Power factor	Full load torque	Direct on line starting torque ratio	Direct on line starting current ratio	Direct on line pull out torque ratio	Direct on line pull up torque ratio	Rotor inertia WJk ²	Sound pressure level @ 1m on no load	Weight
P _N Kw (HP)	n min ⁻¹	Type	I _N 400V A	η 1.0P _N 0.75P _N 0.5P _N	Cos φ 1.0P _N 0.75P _N 0.5P _N	M _N Nm	$\frac{M_A}{M_N}$	$\frac{I_A}{I_N}$	$\frac{M_K}{M_N}$	$\frac{M_S}{M_N}$	J kgm ²	L _{PA} dB(A)	kg
55 (75)	2955	WP-UDF250MNE IE3	92.0	$\left\{ \begin{array}{l} 94.6 \\ 94.6 \\ 94.5 \end{array} \right\}$	$\left\{ \begin{array}{l} 0.92 \\ 0.91 \\ 0.86 \end{array} \right\}$	178	2.3	7.8	2.8	1.9	0.56	75	420
75 (100)	2960	WP-UDF280SNE IE3	127	$\left\{ \begin{array}{l} 95.0 \\ 95.1 \\ 95.0 \end{array} \right\}$	$\left\{ \begin{array}{l} 0.90 \\ 0.87 \\ 0.83 \end{array} \right\}$	242	2.2	7.8	3.0	2.0	0.70	77	570
90 (125)	2960	WP-UDF280MNE IE3	150	$\left\{ \begin{array}{l} 95.5 \\ 95.5 \\ 95.3 \end{array} \right\}$	$\left\{ \begin{array}{l} 0.91 \\ 0.88 \\ 0.82 \end{array} \right\}$	290	2.2	7.8	3.0	2.0	0.80	77	660
110 (150)	2980	WP-UDF315SNE IE3	183	$\left\{ \begin{array}{l} 95.2 \\ 95.2 \\ 95.2 \end{array} \right\}$	$\left\{ \begin{array}{l} 0.91 \\ 0.89 \\ 0.84 \end{array} \right\}$	353	2.2	7.8	2.9	1.8	1.40	78	800
132 (175)	2975	WP-UDF315MNE IE3	222	$\left\{ \begin{array}{l} 95.4 \\ 95.5 \\ 94.8 \end{array} \right\}$	$\left\{ \begin{array}{l} 0.90 \\ 0.89 \\ 0.85 \end{array} \right\}$	423.7	2.2	7.8	2.9	1.8	1.70		
150 (200)	2980	WP-UDF315MN IE3	249	$\left\{ \begin{array}{l} 95.5 \\ 95.3 \\ 94.1 \end{array} \right\}$	$\left\{ \begin{array}{l} 0.91 \\ 0.89 \\ 0.84 \end{array} \right\}$	480.7	2.0	7.8	2.75	1.7	2.40		
160 (215)	2980	WP-UDF315MP IE3	265	$\left\{ \begin{array}{l} 95.6 \\ 95.5 \\ 94.5 \end{array} \right\}$	$\left\{ \begin{array}{l} 0.91 \\ 0.89 \\ 0.83 \end{array} \right\}$	512.8	2.0	7.8	2.75	1.7	2.60		
185 (250)	2975	WP-UDF315LN IE3	304	$\left\{ \begin{array}{l} 95.7 \\ 95.7 \\ 95.0 \end{array} \right\}$	$\left\{ \begin{array}{l} 0.92 \\ 0.89 \\ 0.85 \end{array} \right\}$	594	2.0	7.8	2.75	1.7	2.80	80	1300
200 (270)	2980	WP-UDF315LP IE3	328	$\left\{ \begin{array}{l} 95.8 \\ 95.8 \\ 95.3 \end{array} \right\}$	$\left\{ \begin{array}{l} 0.92 \\ 0.90 \\ 0.86 \end{array} \right\}$	641	2.1	7.9	2.9	1.6		80	
225 (300)	2985	WP-UDF355SG IE3	381	$\left\{ \begin{array}{l} 95.8 \\ 95.4 \\ 94.4 \end{array} \right\}$	$\left\{ \begin{array}{l} 0.89 \\ 0.86 \\ 0.82 \end{array} \right\}$	719.8	2.0	7.5	2.7	1.6	5.00		
250 (335)	2980	WP-UDF355SJ IE3	419	$\left\{ \begin{array}{l} 95.8 \\ 95.2 \\ 93.8 \end{array} \right\}$	$\left\{ \begin{array}{l} 0.90 \\ 0.86 \\ 0.81 \end{array} \right\}$	801.2	2.0	7.5	2.7	1.6	5.30		
280 (375)	2980	WP-UDF355SN IE3	474	$\left\{ \begin{array}{l} 95.8 \\ 95.3 \\ 94.2 \end{array} \right\}$	$\left\{ \begin{array}{l} 0.89 \\ 0.88 \\ 0.84 \end{array} \right\}$	897.3	2.0	7.5	2.7	1.6	5.90		
315 (420)	2985	WP-UDF355MJ IE3	533	$\left\{ \begin{array}{l} 95.8 \\ 95.8 \\ 95.0 \end{array} \right\}$	$\left\{ \begin{array}{l} 0.89 \\ 0.88 \\ 0.85 \end{array} \right\}$	1007.8	2.0	7.5	2.7	1.6	6.30		
355 (475)	2985	WP-UDF355MN IE3	600	$\left\{ \begin{array}{l} 95.8 \\ 95.8 \\ 95.0 \end{array} \right\}$	$\left\{ \begin{array}{l} 0.89 \\ 0.88 \\ 0.85 \end{array} \right\}$	1136	2.0	7.5	2.7	1.6	7.00		
375 (503)	2985	WP-UDF355LN IE3	621	$\left\{ \begin{array}{l} 95.8 \\ 95.8 \\ 95.3 \end{array} \right\}$	$\left\{ \begin{array}{l} 0.91 \\ 0.90 \\ 0.85 \end{array} \right\}$	1200	2.6	7.3	3.2	2.0	8.00	80	2500

Performance data - cast iron frame

1500 min⁻¹ (4 pole)

Rated power	Full load speed in revolutions per minute	Frame reference and size	Full load current at rated voltage	Efficiency	Power factor	Full load torque	Direct on line starting torque ratio	Direct on line starting current ratio	Direct on line pull out torque ratio	Direct on line pull up torque ratio	Rotor inertia WJ ²	Sound pressure level @ 1m on no load	Weight
P _N Kw (HP)	n min ⁻¹	Type	I _N 400V A	η 1.0P _N 0.75P _N 0.5P _N	Cos φ 1.0P _N 0.75P _N 0.5P _N	M _N Nm	$\frac{M_A}{M_N}$	$\frac{I_A}{I_N}$	$\frac{M_K}{M_N}$	$\frac{M_S}{M_N}$	J kgm ²	L _{PA} dB(A)	kg
1.1 (1.5)	1430	WP-DF90STX IE3	2.50	84.1 84.4 84.0	0.77 0.70 0.57	7.3	3.0	7.0	3.5	2.7	0.0037	48	
1.5 (2.0)	1440	WP-DF90LWX IE3	3.60	85.3 85.3 83.2	0.70 0.58 0.46	9.9	4.2	7.4	4.7	4.1	0.0042	48	35
2.2 (3.0)	1450	WP-DF100LRF IE3	4.60	86.7 87.0 86.0	0.79 0.70 0.57	14.5	3.3	7.3	3.3	3.0		54	
3.0 (4.0)	1460	WP-DF100LTF IE3	6.70	87.7 87.7 85.8	0.74 0.63 0.50	19.6	3.9	8.1	4.0	3.2	0.0118	54	55.2
4.0 (5.5)	1450	WP-DF112MWX IE3	8.4	88.6 88.6 88.0	0.78 0.70 0.56	26.3	3.5	8.0	3.5	2.9			
5.5 (7.5)	1460	WP-DF132STX IE3	10.9	89.6 90.0 88.7	0.81 0.73 0.60	36.0	3.3	8.7	3.9	2.7	0.030	59	78.1
7.5 (10)	1450	WP-DF132MVX IE3	14.6	90.4 91.3 90.4	0.82 0.73 0.60	49.4	3.2	7.6	3.4	2.6	0.033	59	82.6
11 (15)	1475	WP-DF160MR IE3	20.9	92.5 92.8 92.0	0.82 0.75 0.62	71.2	3.0	9.0	3.7	2.4	0.084	63	
15 (20)	1475	WP-DF160LU IE3	28.1	92.8 93.0 92.3	0.83 0.76 0.62	97.1	3.2	9.1	3.5	2.4	0.098	63	
18.5 (25)	1475	WP-DF180ME IE3	34.7	92.6 92.8 92.0	0.83 0.74 0.60	120	2.4	8.4	3.0	2.0	0.16	62	162
22 (30)	1470	WP-DF180LM IE3	41.1	93.0 93.0 93.0	0.83 0.75 0.62	143	2.4	8.8	3.0	2.0	0.17	62	
30 (40)	1470	WP-UDF200LNX IE3	54.0	93.6 93.6 93.0	0.86 0.83 0.75	195	2.3	7.5	3.2	1.9	0.31	65	270
37 (50)	1475	WP-UDF225SR IE3	64.5	93.9 93.9 93.0	0.88 0.82 0.74	240	2.7	8.4	2.9	2.1		66	
45 (60)	1480	WP-UDF225MN IE3	80.0	94.2 94.3 93.5	0.86 0.84 0.75	290	2.7	7.7	3.2	1.9	0.65	67	375

Performance data - cast iron frame

1500 min⁻¹ (4 pole)

Rated power	Full load speed in revolutions per minute	Frame reference and size	Full load current at rated voltage	Efficiency	Power factor	Full load torque	Direct on line starting torque ratio	Direct on line starting current ratio	Direct on line pull out torque ratio	Direct on line pull up torque ratio	Rotor inertia Wk ²	Sound pressure level @ 1m on no load	Weight
P _N Kw (HP)	n min ⁻¹	Type	I _N 400V A	η 1.0P _N 0.75P _N 0.5P _N	Cos φ 1.0P _N 0.75P _N 0.5P _N	M _N Nm	$\frac{M_A}{M_N}$	$\frac{I_A}{I_N}$	$\frac{M_K}{M_N}$	$\frac{M_S}{M_N}$	J kgm ²	L _{PA} dB(A)	kg
55 (75)	1475	WP-UDF250MPE IE3	95.5	94.6 94.8 94.2	0.88 0.84 0.76	356	2.7	8.3	2.9	2.2		67	
75 (100)	1480	WP-UDF280SNE IE3	134	95.0 95.1 95.0	0.85 0.83 0.76	484	2.4	7.4	2.7	1.9			
90 (125)	1480	WP-UDF280MNE IE3	158	95.2 95.2 95.0	0.86 0.82 0.76	581	2.5	7.4	2.8	2.0	1.6		
110 (150)	1485	WP-UDF315SNE IE3	191	95.8 95.8 95.3	0.87 0.85 0.77	707	2.4	7.7	2.6	2.0	3.2	71	800
132 (175)	1485	WP-UDF315MNE IE3	229	95.6 95.6 95.5	0.87 0.85 0.77	849	2.4	7.7	2.6	2.0	3.7	71	1000
150 (200)	1490	WP-UDF315MN IE3	254	96.0 96.1 95.5	0.89 0.85 0.77	961	2.4	7.8	2.7	2.0	4.4	73	1100
160 (215)	1490	WP-UDF315MP IE3	268	96.0 96.0 95.9	0.90 0.88 0.80	1025	2.4	7.8	2.7	2.0	4.7	73	1150
185 (250)	1490	WP-UDF315LN IE3	309	96.0 96.0 95.9	0.90 0.86 0.79	1186	2.4	7.8	2.7	2.0	5.5	73	1300
200 (270)	1490	WP-UDF315LN IE3	334	96.0 96.0 95.9	0.90 0.86 0.79	1282	2.3	7.6	2.6	1.9	5.5	73	1300
225 (300)	1490	WP-UDF355SG IE3	383	96.4 96.4 96.0	0.88 0.86 0.80	1442	2.0	6.6	2.3	1.6	8.2	76	1900
250 (335)	1485	WP-UDF355SJ IE3	427	96.0 96.0 95.4	0.88 0.86 0.80	1608	2.0	6.5	2.5	1.6	9.5	76	2000
280 (375)	1490	WP-UDF355SN IE3	478	96.0 96.0 95.5	0.88 0.86 0.80	1795	2.1	7.2	2.5	1.7	10.6	76	2100
315 (420)	1490	WP-UDF355MJ IE3	538	96.0 96.1 95.7	0.88 0.87 0.83	2019	2.1	7.2	2.5	1.7	11.9	79	2200
355 (475)	1490	WP-UDF355MN IE3	600	96.0 96.3 96.2	0.89 0.88 0.83	2275	2.2	6.8	2.5	1.7	13.2		
375 (503)	1490	WP-UDF355LN IE3	633	96.2 96.5 96.4	0.89 0.88 0.83	2404	2.4	7.4	2.6	1.8	14.6	79	2500

Performance data - cast iron frame

1000 min⁻¹ (6 pole)

Rated power	Full load speed in revolutions per minute	Frame reference and size	Full load current at rated voltage	Efficiency	Power factor	Full load torque	Direct on line starting torque ratio	Direct on line starting current ratio	Direct on line pull out torque ratio	Direct on line pull up torque ratio	Rotor inertia Wk ²	Sound pressure level @ 1m on no load	Weight
P _N Kw (HP)	n min ⁻¹	Type	I _N 400V A	η 1.0P _N 0.75P _N 0.5P _N	Cos φ 1.0P _N 0.75P _N 0.5P _N	M _N Nm	$\frac{M_A}{M_N}$	$\frac{I_A}{I_N}$	$\frac{M_K}{M_N}$	$\frac{M_S}{M_N}$	J kgm ²	L _{PA} dB(A)	kg
1.5 (2.0)	960	WP-DF100LRF IE3	4.7	82.5 82.1 78.9	0.56 0.48 0.37	14.9	3.9	6.4	4.6	3.6			
2.2 (3.0)	960	WP-DF112MWX IE3	5.8	84.3 84.4 81.8	0.65 0.58 0.43	21.9	2.8	5.6	3.0	2.4	0.015		
3.0 (4.0)	970	WP-DF132MMX IE3	7.2	87.0 86.7 83.0	0.69 0.62 0.43	29.5	2.3	6.1	2.5	2.2			
4.0 (5.5)	960	WP-DF132STX IE3	9.8	86.8 86.5 83.3	0.68 0.59 0.49	39.8	2.3	5.5	2.5	2.1			
5.5 (7.5)	965	WP-DF132MVX IE3	13.3	88.0 87 84	0.68 0.53 0.42	54.4	2.6	6.5	3.0	1.9			
7.5 (10)	975	WP-DF160MM IE3	16.6	89.1 89.1 89.2	0.73 0.65 0.56	73.5	1.7	5.1	1.6	1.3	0.10		
11 (15)	980	WP-DF160LV IE3	22.4	90.3 90.3 90.0	0.75 0.69 0.53	107.2	2.0	7.5	2.8	1.9	0.12		
15 (20)	980	WP-DF180LR IE3	30.4	91.2 91.5 90.5	0.78 0.72 0.61	146.2	2.0	6.0	2.4	1.5			
18.5 (25)	980	WP-DF200LNX IE3	36.4	91.7 91.7 90.8	0.80 0.73 0.62	180.3	2.4	8.6	2.8	2.8		62	
22 (30)	980	WP-DF200LN IE3	43.6	92.2 92.2 91.7	0.79 0.73 0.63	214.4	2.7	6.8	2.3	2.2		62	
30 (40)	985	WP-UDF225MN IE3	57.5	92.9 92.9 92.3	0.81 0.77 0.68	290.9	2.7	6.0	2.1	1.8	1.23	63	375
37 (50)	985	WP-UDF250MNE IE3	71.0	93.5 93.6 93.1	0.81 0.77 0.68	358.7	2.5	6.0	2.0	1.8	1.47	63	420

Performance data - cast iron frame

1000 min⁻¹ (6 pole)

Rated power	Full load speed in revolutions per minute	Frame reference and size	Full load current at rated voltage	Efficiency	Power factor	Full load torque	Direct on line starting torque ratio	Direct on line starting current ratio	Direct on line pull out torque ratio	Direct on line pull up torque ratio	Rotor inertia Wk ²	Sound pressure level @ 1m on no load	Weight
P _N Kw (HP)	n min ⁻¹	Type	I _N 400V A	η 1.0P _N 0.75P _N 0.5P _N	Cos φ 1.0P _N 0.75P _N 0.5P _N	M _N Nm	$\frac{M_A}{M_N}$	$\frac{I_A}{I_N}$	$\frac{M_K}{M_N}$	$\frac{M_S}{M_N}$	J kgm ²	L _{PA} dB(A)	kg
45 (60)	990	WP-UDF280SNE IE3	85.0	94.0 94.1 93.4	0.81 0.77 0.69	434.1	2.5	6.0	2.0	1.8	2.55	65	570
55 (75)	990	WP-UDF280MNE IE3	104	94.1 94.1 93.2	0.81 0.78 0.71	530.6	2.5	6.1	2.0	1.9	2.9	65	660
75 (100)	990	WP-UDF315SNE IE3	138	94.6 94.6 93.5	0.83 0.80 0.70	723.5	3.0	7.0	2.6	2.1	5.0	68	800
90 (125)	990	WP-UDF315MNE IE3	165	94.9 94.9 93.0	0.83 0.77 0.67	868.2	3.0	7.0	2.6	2.1	6.0		
110 (150)	988	WP-UDF315MN IE3	196	95.4 95.5 95.0	0.85 0.83 0.77	1063	2.8	6.7	2.0	1.9	6.1		
132 (175)	985	WP-UDF315LN IE3	235	95.4 95.4 94.5	0.85 0.82 0.75	1280	3.0	8.0	2.5	2.4	7.3		
150 (200)	987	WP-UDF355SG IE3	270	95.5 95.5 94.7	0.84 0.82 0.74	1451.4	1.7	7.0	2.1	1.4	10.0		
160 (215)	990	WP-UDF355SG IE3	295	95.8 95.9 94.9	0.82 0.77 0.69	1543.4	1.7	6.7	2.1	1.4	10.0		
185 (250)	990	WP-UDF355SJ IE3	328	95.7 95.8 95.0	0.85 0.84 0.77	1784.6	1.7	6.7	2.1	1.4	11.1		
200 (270)		WP-UDF355SP IE3											
225 (300)	990	WP-UDF355MN IE3	394	95.8 93.7 95.5	0.86 0.82 0.74	2170	1.7	6.7	2.1	1.4			
250 (335)	990	WP-UDF355MN IE3	446	96.2 96.3 95.9	0.84 0.81 0.74	2411.6	1.8	7.0	2.2	1.5	15.2		
280 (375)	990	WP-UDF355LJ IE3	502	95.8 95.9 95.4	0.84 0.79 0.69	2701	1.8	7.0	2.2	1.5	16.9		
315 (420)	990	WP-UDF355LN IE3	552	95.8 95.9 95.5	0.86 0.84 0.77	3038	1.8	7.0	2.1	1.5	18.6	77	2500

Dimensions - aluminium frame

Shaft		
Dim D	British and European	
	Tol	Limits
19 to 28	j6	+0,009 - 0,004
32 to 48	k6	+0,018 - 0,002

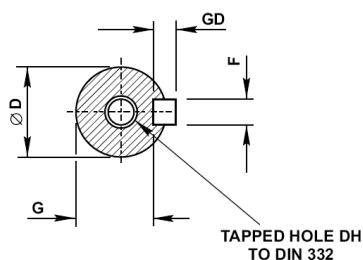

Flange		
Dim N	IEC 72-1	
	Tol	Limits
130 to 180	j6	+0.014 - 0.011
230 to 250	h6	+0.016 - 0.013

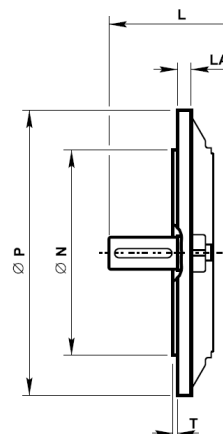

Face		
Dim N	IEC 72-1	
	Tol	Limits
95 to 110	j6	+0.013 - 0.009
130 to 180	j6	+0.014 - 0.011

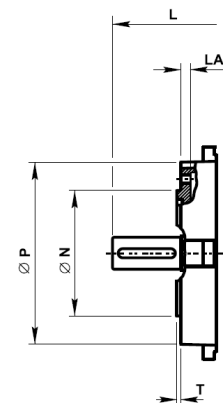

Notes

- All dimensions in millimetres
- Drain holes are standard on frames 160-180 and on request for frames 80-132
- Cable entry can be arranged in any one of four positions at 90° intervals
- No eyebolts on frame sizes 80-90
- On frame sizes 80 the terminal box is offset towards the non-drive end
- Dimensions should not be used for installation purposes unless specially endorsed

Notes

- B5 mounted motors have suffix '-D' in the frame reference, eg WU-DA132MRX-D and B3/B5 mounted motors have suffix '-H' in the frame reference, eg WU-DA132MRX-H
- B14 mounted motors have suffix 'C' in the frame reference, eg WU-DA132MRX-C and B3/B14 mounted motors have suffix '-H' in the frame reference, eg WU-DA132MRX-H
- Pad mounted motors have suffix '-P' in the frame reference, eg WU-DA132MRX-P

Dimensions - aluminium frame

Foot (B3) / Flange (B5) / Face mounting (B14) - TEFV

IM B3
IM 1001
Mounting options

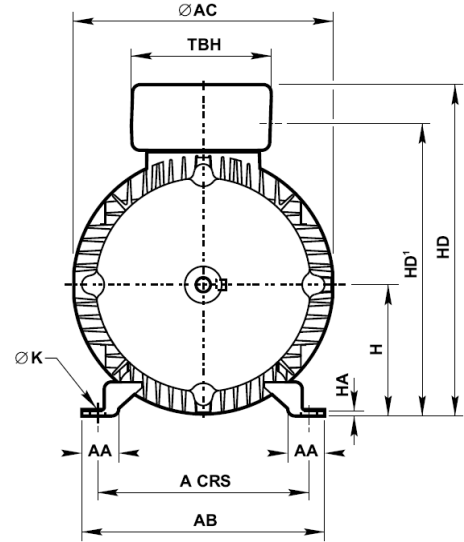
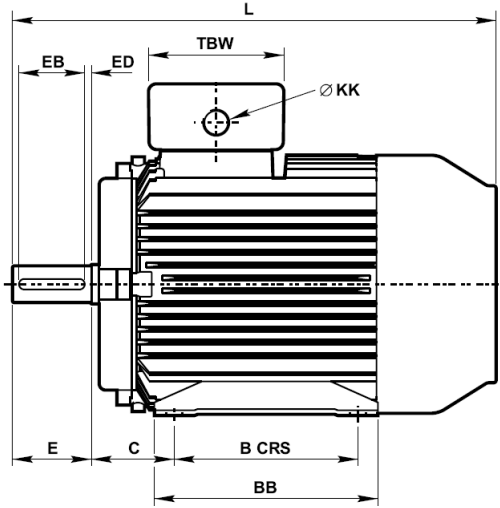

IM B5/IM B35
IM 3001/IM 2001
Mounting options

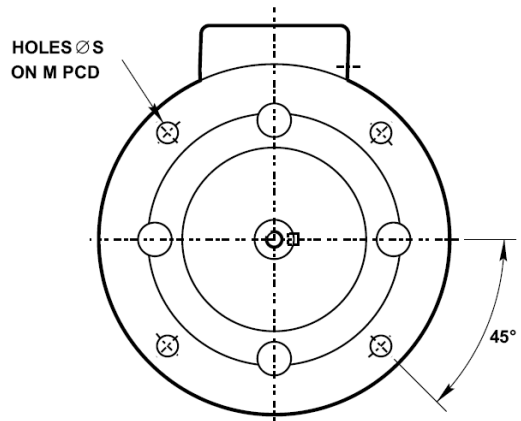
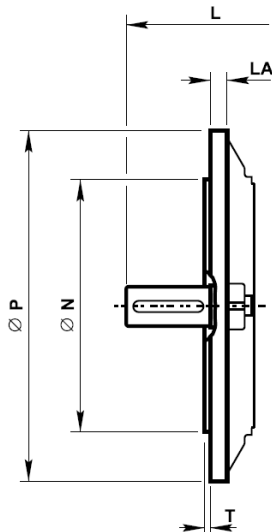

IM B14/IM B34
IM 3601/IM 2101
Mounting options

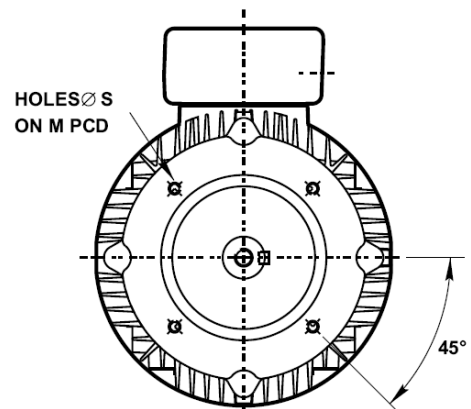
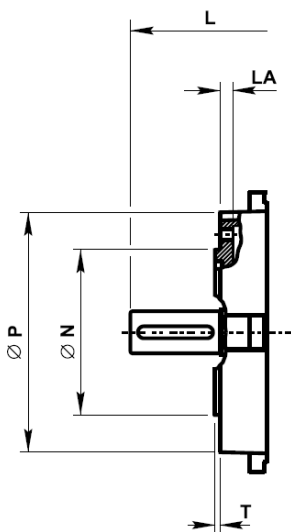

Dimensions - aluminium frame

Foot (B3) / Flange (B5) / Face mounting (B14) - TEFV

Type	General													Terminal box		
	A	B	C	H	K	L	AA	AB	AC	BB	HA	HD	HD ¹	TBW	TBH	KK
WP-DA80M	125	100	50	80	10	278	27	157	160	127	4	212	183	86	86	1 x M20
WP-DA90SX	140	100	56	90	10	349	28	164	178	150	4	225	201	86	86	1 x M20
WP-DA90LX	140	125	56	90	10	349	28	164	178	150	4	225	201	86	86	1 x M20
WP-DA100LF	160	140	63	100	12	442	28	184	215	170	4	267	233	127	127	2 x M20
WP-DA112M	190	140	70	112	12	382	35	218	215	170	4	279	245	127	127	2 x M25
WP-DA112MX	190	140	70	112	12	442	35	219	207	170	4	279	246	127	127	1 x M25
WP-DA132SX	216	140	89	132	12	489	38	242	255	208	5	322	289	127	127	2 x M25
WP-DA132MX	216	178	89	132	12	489	38	242	255	208	5	322	289	127	127	2 x M25
WP-DA160M	254	210	108	160	15	605	49	304	314	304	5	400	359	140	140	2 x M32
WP-DA160L	254	254	108	160	15	605	49	304	314	304	5	400	359	140	140	2 x M32
WP-DA180M	279	241	121	180	15	667	50	329	358	329	6	440	396	140	140	2 x M32
WP-DA180L	279	279	121	180	15	667	50	329	358	329	6	440	396	140	140	2 x M32

Type	IM B5 mounting						IM B14 mounting					
	M	N	P	S	T	LA	M	N	P	S	T	LA
WP-DA80M	165	130	200	12	3.5	12	100	80	120	M6	3	9
WP-DA90SX	165	130	200	12	3.5	10	115	95	140	M8	3	9
WP-DA90LX	165	130	200	12	3.5	10	115	95	140	M8	3	9
WP-DA100LF	215	180	250	14.5	4	12	130	110	160	M8	3.5	12.5
WP-DA112M	215	180	250	14.5	4	12	130	110	164	M8	3.5	13
WP-DA112MX	215	180	250	15.5	4	12	130	110	164	M8	3.5	13
WP-DA132SX	265	230	300	14.5	4	12	165	130	200	M10	3.5	14
WP-DA132MX	265	230	300	14.5	4	12	165	130	200	M10	3.5	14
WP-DA160M	300	250	350	18.5	5	13	215	180	250	M12	4	13
WP-DA160L	300	250	350	18.5	5	13	215	180	250	M12	4	13
WP-DA180M	300	250	350	18.5	5	15	-	-	-	-	-	-
WP-DA180L	300	250	350	18.5	5	15	-	-	-	-	-	-

Type	Shaft							
	D	E	F	G	GD	EB	ED	DH
WP-DA80M	19	40	6	15.5	6	32	4	M6x16
WP-DA90SX	24	50	8	20	7	40	5	M8x19
WP-DA90LX	24	50	8	20	7	40	5	M8x19
WP-DA100LF	28	60	8	23.9	7	50	5	M10x22
WP-DA112M	28	60	8	23.9	7	50	5	M10x22
WP-DA112MX	28	60	8	23.9	7	50	5	M10x22
WP-DA132SX	38	80	10	33	8	70	5	M12x28
WP-DA132MX	38	80	10	33	8	70	5	M12x28
WP-DA160M	42	110	12	37	8	100	5	M16x36
WP-DA160L	42	110	12	37	8	100	5	M16x36
WP-DA180M	48	110	14	42.5	9	100	5	M16x36
WP-DA180L	48	110	14	42.5	9	100	5	M16x36

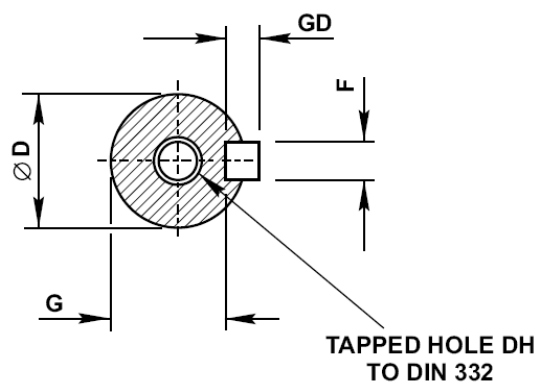

Dimensions - aluminium frame

Pad/rod mounting (B30) - AOM

IM B30, IM V30, IM V31
 IM 9201, IM 9211, IM 9231
 Mounting options

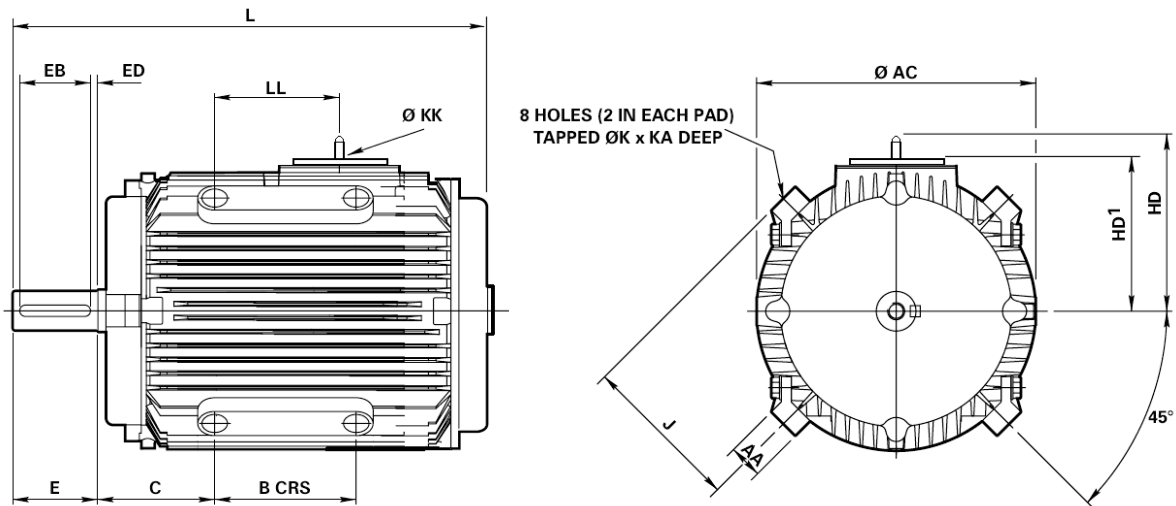

Type	Pad / rod mounting: general											
	B	C	J	K	L	AA	AC	HD	HD1	KA	KK	LL
WP-DA80M-P	90	55	95	M12	253	23	160	-	96	14	M20	67.5
WP-DA90LX-P	90	73.5	103	M12	327	24	178	-	104	13	M20	80.5
WP-DA100LF-P ¹	100	90	125	M12	395	24	215	154	133	18	M25	88
WP-DA112M-P	100	90	125	M12	336	24	215	154	133	18	M25	85
WP-DA132MX-P	140	108	150	M16	430	35	255	175	145	19	M25	96
WP-DA160L-P	200	135	181	M20	533	35	314	208.5	181	22	M32	158
WP-DA180L-P	200	160.5	202	M20	590	35	358	238	202	22	M32	161

Type	Shaft							
	D	E	F	G	GD	EB	ED	DH
WP-DA80M	19	40	6	15.5	6	32	4	M6x16
WP-DA90LX	24	50	8	20	7	40	5	M8x19
WP-DA100LF ¹	28	60	8	23.9	7	50	5	M10x22
WP-DA112M	28	60	8	23.9	7	50	5	M10x22
WP-DA132MX	38	80	10	33	8	70	5	M12x28
WP-DA160L	42	110	12	37	8	100	5	M16x36
WP-DA180L	48	110	14	42.5	9	100	5	M16x36

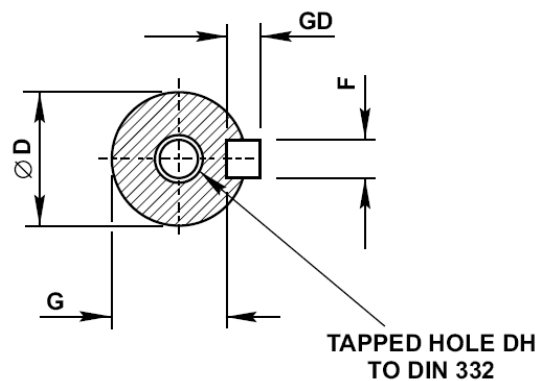

1 - New mechanical design required

Dimensions - cast iron frame

Shaft		
Dim D	British and European	
	Tol	Limits
19 to 28	j6	+0,009 - 0,004
32 to 48	k6	+0,018 - 0,002
55 to 80	m6	+0.030 +0.011
85 to 110	m6	+0.035 +0.013

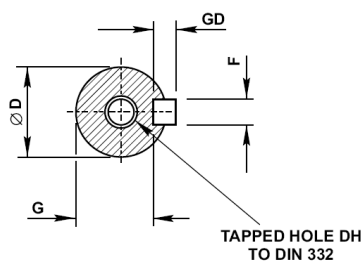

Flange	Face	Tolerance to IEC 60072-1	
		Tol	Limits
—	80	j6	+0.012 -0.007
—	95 to 110	j6	+0.013 - 0.009
130 to 180	130 to 180	j6	+0.014 - 0.011
230 to 250	—	h6	+0.016 - 0.013
300	—	h6	+0.000 -0.032
350	—	h6	+0.000 -0.036
450	—	h6	+0.000 -0.040
550	—	h6	+0.000 -0.044
680	—	h6	+0.000 -0.050

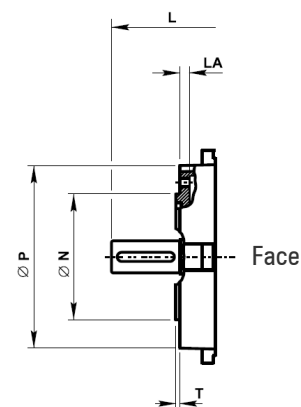
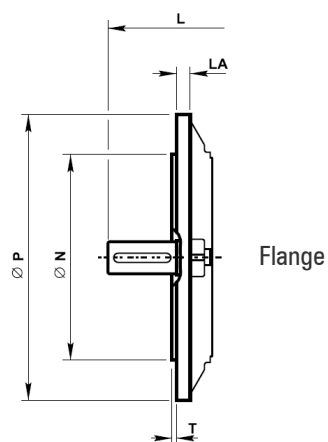

Notes

- All dimensions in millimetres
- Drain holes are standard on frames 160-355 and on request for frames 80-132
- Please note that 80 frame motors are available as terminal box right or left.
- Cable entry can be arranged in any one of four positions at 90° intervals
- No eyebolts on frame sizes 80 (all poles) and 90 (6p and 8p)
- Dimensions should not be used for installation purposes unless specially endorsed

Notes

- B5 mounted motors have suffix '-D' in the frame reference, eg WU-DF132MVX-D and B3/B5 mounted motors have suffix '-H' in the frame reference, eg WU-DF132MVX-H
- B14 mounted motors have suffix 'C' in the frame reference, eg WU-DF132MVX-C and B3/B14 mounted motors have suffix '-H' in the frame reference, eg WU-DF132MVX-H
- Pad mounted motors have suffix '-P' in the frame reference, eg WU-DF132MVX-P

Dimensions - cast iron frame - European and BS specification

Foot (B3) / Flange (B5) / Face mounting (B14) - TEFV frames 80-180

IM B3
IM 1001
Mounting options

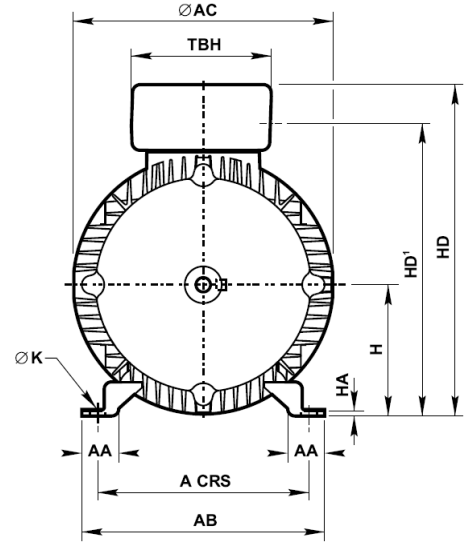
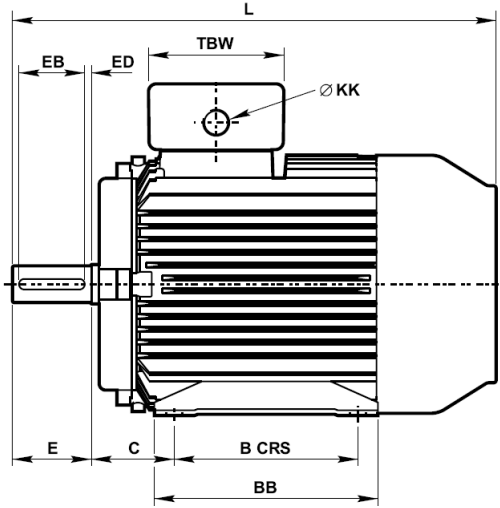

IM B5/IM B35
IM 3001/IM 2001
Mounting options

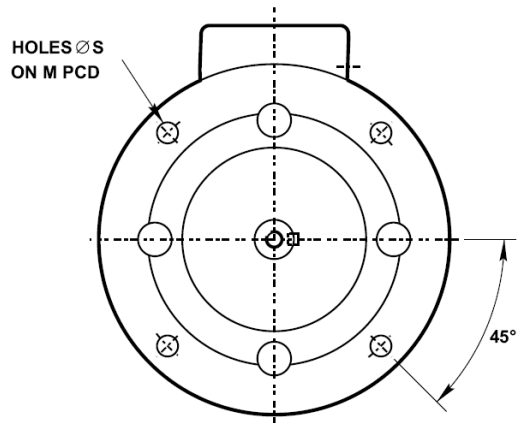
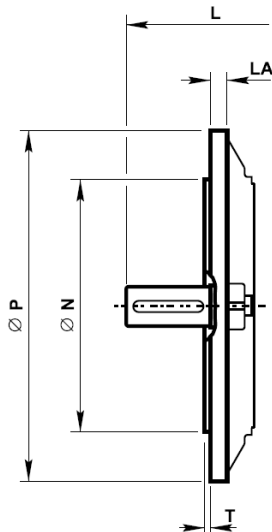

IM B14/IM B34
IM 3601/IM 2101
Mounting options

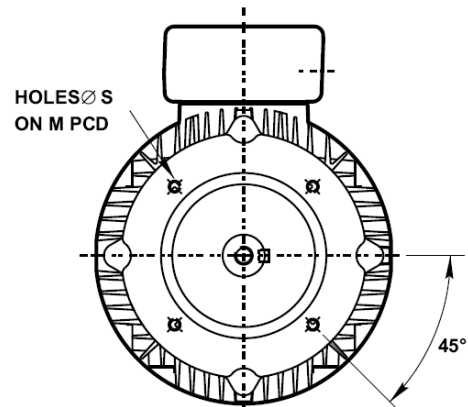
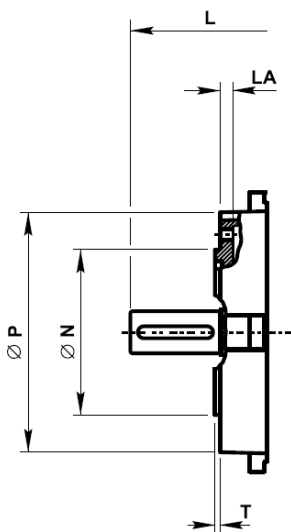

Dimensions - cast iron frame - European and BS specification

Foot (B3) / Flange (B5) / Face mounting (B14) - TEFV frames 80-180

Type	General													Terminal box		
	A	B	C	H	K	L	AA	AB	AC	BB	HA	HD	HD ¹	TBW	TBH	KK
WP-DF80M	125	100	50	80	10	278	35	157	158	127	10	236	195	120	120	1x M20
WP-DF90LX	140	125	56	90	10	364	38	175	174	195	12	254	273	120	120	1x M20
WP-DF90SX	140	125	56	90	10	364	35	175	174	155	12	254	212	120	120	1xM20
WP-DF100LF	160	140	63	100	12	409	34	195	214	206	14	283	242	120	120	2x M20
WP-DF112M	190	140	70	112	12	382	40	230	220	182	16	305	258	135	135	2x M25
WP-DF112MX	190	140	70	112	12	442	40	230	214	182	16	305	258	135	135	2xM25
WP-DF132S	216	140	89	132	12	447	47	255	260	220	17	348	308	135	135	2x M25
WP-DF132SX	216	140	89	132	12	484	47	255	256	220	16	348	300	135	135	2x M25
WP-DF132MX	216	178	89	132	12	484	47	255	256	220	16	348	300	135	135	2x M25
WP-DF160M	254	210	108	160	15	604	55	300	315	300	22	428	368	174	174	2x M32
WP-DF160L	254	254	108	160	15	604	55	300	315	300	22	428	368	174	174	2x M32
WP-DF180M	279	241	121	180	15	663	64	344	355	326	22	469	410	174	174	2x M32
WP-DF180L	279	279	121	180	15	663	64	344	355	326	22	469	410	174	174	2x M32

Type	IM B5 mounting						IM B14 mounting					
	M	N	P	S	T	LA	M	N	P	S	T	LA
WP-DF80M	165	130	200	12	3.5	12	100	80	120	M6	3	9
WP-DF90LX	165	130	200	12	3.5	10	115	95	140	M8	3	9
WP-DF90SX	165	130	200	12	3.5	12	115	95	140	M8	3	9
WP-DF100LF	215	180	250	14.5	4	12	130	110	160	M8	3.5	12.5
WP-DF112M	215	180	250	14.5	4	12	130	110	164	M8	3.5	13
WP-DF112MX	215	180	250	14.5	4	12	130	110	164	M8	3.5	13
WP-DF132S	265	230	300	14.5	4	12	165	130	200	M10	3.5	14
WP-DF132SX	265	230	300	14.5	4	12	165	130	200	M10	3.5	14
WP-DF132MX	265	230	300	14.5	4	12	165	130	200	M10	3.5	14
WP-DF160M	300	250	350	18.5	5	13	215	180	250	M12	4	13
WP-DF160L	300	250	350	18.5	5	13	215	180	250	M12	4	13
WP-DF180M	300	250	350	18.5	5	15	-	-	-	-	-	-
WP-DF180L	300	250	350	18.5	5	15	-	-	-	-	-	-

Type	Shaft							
	D	E	F	G	GD	EB	ED	DH
WP-DF80M	19	40	6	15.5	6	32	4	M6x16
WP-DF90LX	24	50	8	20	7	40	5	M8x19
WP-DF90SX	24	50	8	20	7	40	5	M8x19
WP-DF100LF	28	60	8	23.9	7	50	5	M10x22
WP-DF112M	28	60	8	23.9	7	50	5	M10x22
WP-DF112MX	28	60	8	24	7	50	5	M10x22
WP-DF132S	38	80	10	33	8	70	5	M12x28
WP-DF132SX	38	80	10	33	8	70	5	M12x28
WP-DF132MX	38	80	10	33	8	70	5	M12x28
WP-DF160M	42	110	12	37	8	100	5	M16x36
WP-DF160L	42	110	12	37	8	100	5	M16x36
WP-DF180M	48	110	14	42.5	9	100	5	M16x36
WP-DF180L	48	110	14	42.5	9	100	5	M16x36

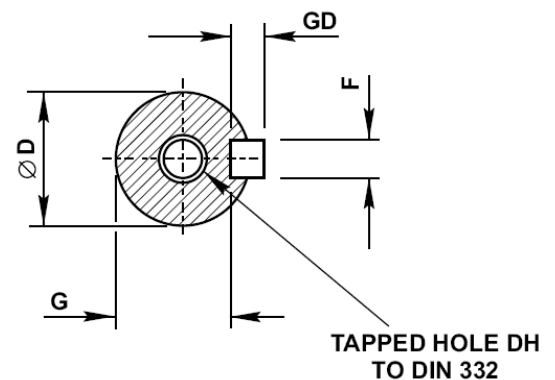

Dimensions - cast iron frame - European specification

Foot (B3) / Flange (B5) - TEFV frames 200 - 355

IM B3
IM 1001
Mounting options

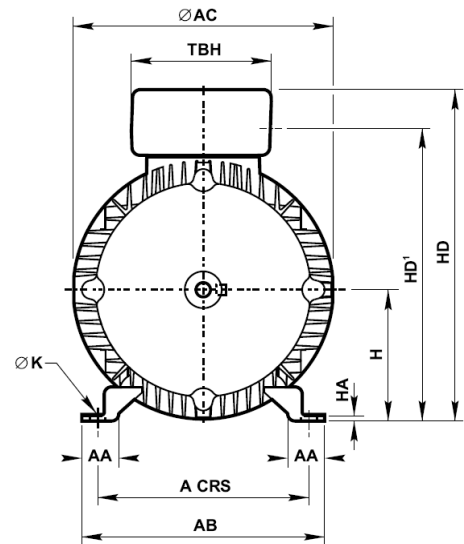
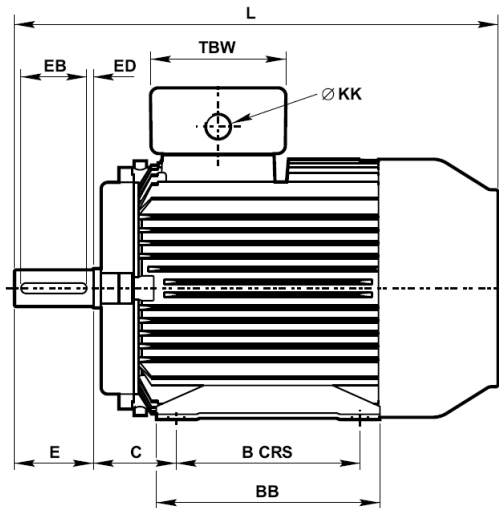

IM B5/IM B35
IM 3001/IM 2001
Mounting options

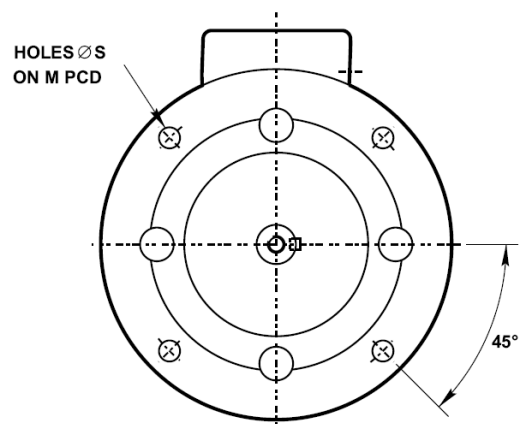
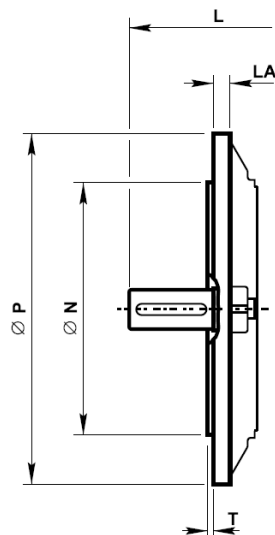

Dimensions - cast iron frame - European specification

Foot (B3) / Flange (B5) - TEFV frames 200 - 355

Type	General													Terminal box					
	A	B	C	H	K	4 pole +		2 pole		AA	AB	AC	BB	HA	HD	HD ¹	TBW	TBH	KK
WP-UDF200LX	318	305	133	200	M16	L	L	74	382	381	359	30	501	444	176	220	220	220	2 x M32 + 1 x M20
WP-UDF225M	356	311	149	225	M16	915	885	70	426	448	374	25	570	510	220	161	220	161	2 x M40 + 1 x M20
WP-UDF225S	356	286	149	225	M16	875	845	70	426	410	349	25	550 ¹	488	220	161	220	161	2 x M40 + 1 x M20
WP-UDF250ME	406	349	168	250	M20	985	985	79	482	448	419	28	595 ²	535	220	161	220	161	2 x M50 + 1 x M20
WP-UDF280SE	457	368	190	280	M20	1065	1065	83	540	508	438	35	655 ¹	595	220	161	220	161	2 x M50 + 1 x M20
WP-UDF280ME	457	419	190	280	M20	1070	1070	83	540	508	489	35	655 ¹	595	220	161	220	161	2 x M50 + 1 x M20
WP-UDF315SE	508	406	216	315	M24	1145	1115	89	597	563	482	38	845	744	330	326	220	161	2 x M63 + 1 x M20
WP-UDF315ME	508	457	216	315	M24	1215	1185	89	597	563	533	38	845	744	330	326	220	161	2 x M63 + 1 x M20
WP-UDF315M	508	457	216	315	M24	1245	1215	89	597	640	533	38	875	776	330	326	220	161	2 x M63 + 1 x M20
WP-UDF315L	508	508	216	315	M24	1315	1285	89	597	640	583	38	875	776	330	326	220	161	2 x M63 + 1 x M20
WP-UDF355S	610	500	254	355	M24	1485	1415	100	710	732	626	27	975	874	330	326	220	161	2 x M63 + 1 x M20
WP-UDF355M	610	560	254	355	M24	1605	1535	100	710	732	686	27	975	874	330	326	220	161	2 x M63 + 1 x M20
WP-UDF355L	610	630	254	355	M24	1655	1585	100	710	732	756	27	975	874	330	326	220	161	2 x M63 + 1 x M20

Type	4 pole +								2 pole							
	Shaft								Shaft							
	D	E	F	G	GD	EB	ED	DH	D	E	F	G	GD	EB	ED	DH
WP-UDF200LX	55	110	16	49	10	100	5	M20 x 42	55	110	16	49	10	100	5	M20 x 42
WP-UDF225M	60	140	18	53	11	125	5	M20 x 42	55	110	16	49	10	100	5	M20 x 42
WP-UDF225S	60	140	18	53	11	125	5	M20 x 42	55	110	16	49	10	100	5	M20 x 42
WP-UDF250ME	65	140	18	58	11	125	5	M20 x 42	60	140	18	53	11	125	5	M20 x 42
WP-UDF280SE	75	140	20	67,5	12	125	5	M20 x 42	65	140	18	53	11	125	5	M20 x 42
WP-UDF280ME	75	140	20	67,5	12	125	5	M20 x 42	65	140	18	58	11	125	5	M20 x 42
WP-UDF315SE	80	170	22	71	14	160	5	M20 x 42	65	140	18	58	11	125	5	M20 x 42
WP-UDF315ME	80	170	22	71	14	160	5	M20 x 42	65	140	18	58	11	125	5	M20 x 42
WP-UDF315M	80	170	22	71	14	160	5	M20 x 42	65	140	18	58	11	125	5	M20 x 42
WP-UDF315L	80	170	22	71	14	160	5	M20 x 42	65	140	18	58	11	125	5	M20 x 42
WP-UDF355S	100	210	28	90	16	200	5	M24 x 50	75	140	20	67,5	12	125	5	M24 x 50
WP-UDF355M	100	210	28	90	16	200	5	M24 x 50	75	140	20	67,5	12	125	5	M24 x 50
WP-UDF355L	100	210	28	90	16	200	5	M24 x 50	75	140	20	67,5	12	125	5	M24 x 50

Type	IM B5, IM B35 mounting					
	M	N	P	S	T	LA
WP-UDF200LX	350	300	400	19	5	19
WP-UDF225M	400	350	450	19	5	19
WP-UDF225S	400	350	450	19	5	19
WP-UDF250ME	500	450	550	19	5	25
WP-UDF280SE	500	450	550	19	5	25
WP-UDF280ME	500	450	550	19	5	25
WP-UDF315SE	500	450	550	19	5	25
WP-UDF315ME	600	550	660	24	6	29
WP-UDF315M	600	550	660	24	6	29
WP-UDF315L	600	550	660	24	6	29
WP-UDF355S	740	680	800	24	6	28
WP-UDF355M	740	680	800	24	6	28
WP-UDF355L	740	680	800	24	6	28

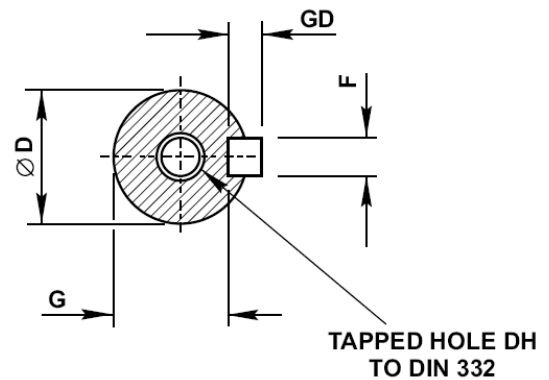

Dimensions - cast iron frame - BS specification

Foot (B3) / Flange (B5) - TEFV frames 200 - 355

IM B3
IM 1001
Mounting options

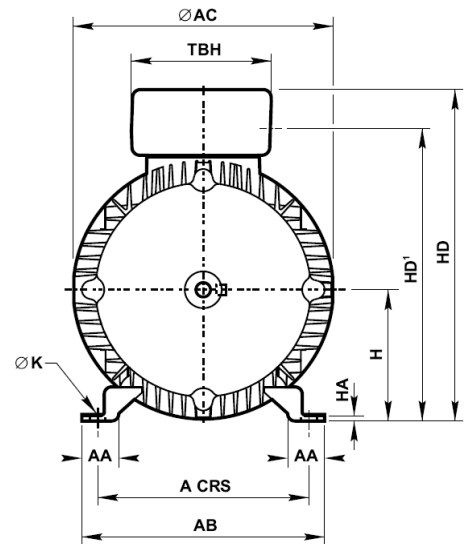
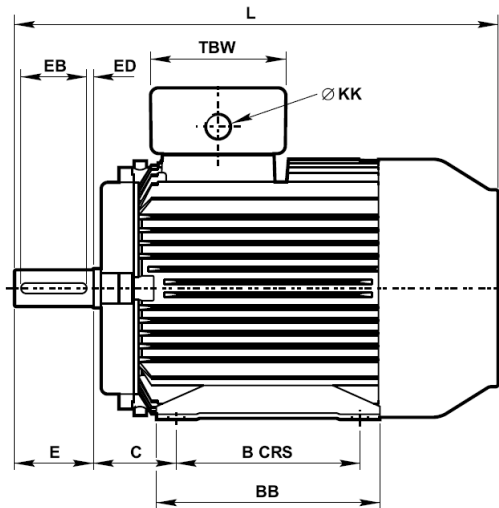

IM B5/IM B35
IM 3001/IM 2001
Mounting options

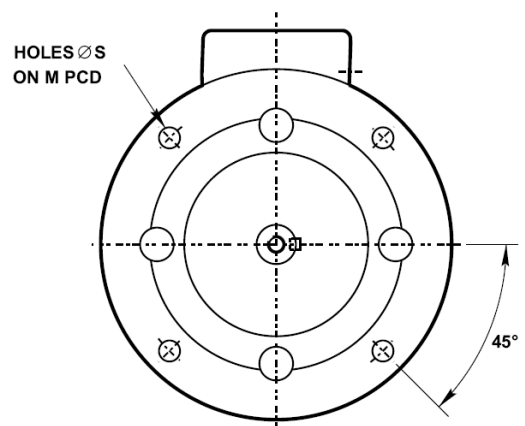
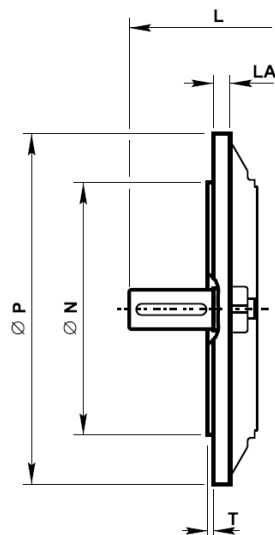

Dimensions - cast iron frame - BS specification

Foot (B3) / Flange (B5) - TEFV frames 200 - 355

Type	General											Terminal box							
	A	B	C	H	K	4 pole +		2 pole		AA	AB	AC	BB	HA	HD	HD ¹	TBW	TBH	KK
WP-DF200LX	318	305	133	200	M16	787	787	74	382	381	359	30	501	444	176	220	2 x M32 + 1 x M20		
WP-DF200L	318	305	133	200	M16	787	787	74	382	381	359	30	501	444	176	220	2 x M32 + 1 x M20		
WP-DF225M	356	311	149	225	M16	915	885	70	426	448	374	25	570	510	220	288	2 x M40 + 1 x M20		

Type	4 pole +								2 pole							
	Shaft								Shaft							
	D	E	F	G	GD	EB	ED	DH	D	E	F	G	GD	EB	ED	DH
WP-DF200LX	55	110	16	49	10	100	5	M20 x 42	55	110	16	49	10	100	5	M20 x 42
WP-DF200L	55	110	16	49	10	100	5	M20 x 42	55	110	16	49	10	100	5	M20 x 42
WP-DF225M	60	140	18	53	11	125	5	M20 x 42	55	110	16	49	10	100	5	M20 x 42

Type	IM B5, IM B35 mounting					
	M	N	P	S	T	LA
WP-DF200LX	350	300	400	19	5	19
WP-DF200L	350	300	400	19	5	19
WP-DF225M	400	350	450	19	5	19

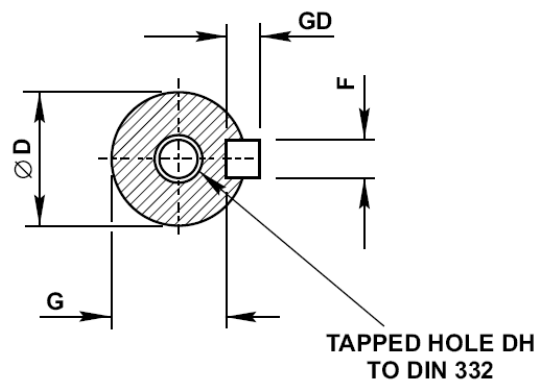

Mounting option

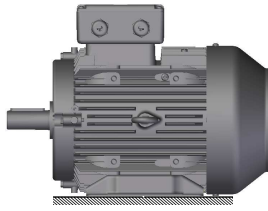

IM B3
IM 1001
foot mounted

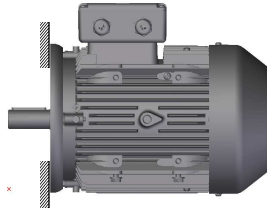

IM B5
IM 3001
flange at DE no feet

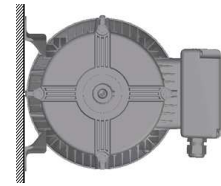

IM B6
IM 1051
foot wall mounted with feet on left hand side

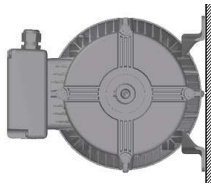

IM B7
IM 1061
foot wall mounted with feet on right hand side

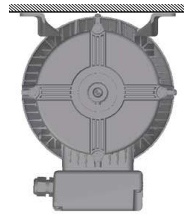

IM B8
IM 1071
ceiling mounted with feet above motor

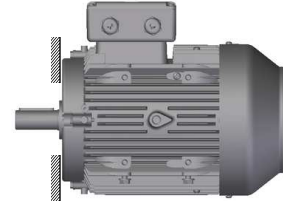

IM B14
IM 3601
face at DE no feet



IM V1
IM 3011
flange at DE shaft down no feet

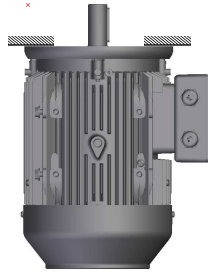

IM V3
IM 3031
flange at DE shaft down no feet



IM V5
IM 1011
vertical foot wall mounted shaft down

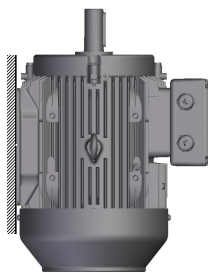

IM V6
IM 1031
vertical foot wall mounted shaft up



IM V18
IM 3611
face at DE no feet shaft down

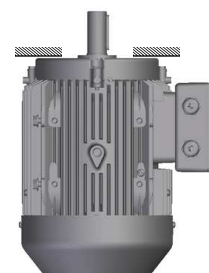

IM V19
IM 3631
face at DE no feet shaft up

Technical information - aluminium frame: Mechanical

Bearing and grease arrangement

Bearings are pre-packed with a lithium complex based grease or Polyurea.

Regreasing facilities are available on request.

Standard and re-greasing facilities

Type	Lithium complex	Polyurea
80 - 180	Esso Unirex N3 with temperature range of -30°C to +140°C	EA6 with temperature range of -40°C to +160°C

Bearing references and oil seals

Type	Mounting	Number of poles	Bearings		Oil seals - bore x O/D x width in mm	
			Drive end	Non-drive end	Drive end	Non-drive end
WP-DA80	All	All	6204ZZ	6003ZZ	20 x 30 x 7	17 x 28 x 6
WP-DA90	All	All	6205ZZ	6203ZZ	25 x 35 x 7	17 x 28 x 6
WP-DA100L	All	All	6206ZZ	6205ZZ	30 x 42 x 7	25 x 37 x 7
WP-DA112	All	All	6206ZZ	6205ZZ	30 x 42 x 7	25 x 37 x 7
WP-DA132	All	All	6208ZZ	6305ZZ	40 x 52 x 7	25 x 37 x 7
WP-DA160	All	All	6309ZZ	6307ZZ	45 x 60 x 8	35 x 47 x 7
WP-DA180	All	All	6310ZZ	6308ZZ	50 x 65 x 8	40 x 52 x 7

Grease life at 80°C temperature x 10³ hours

Type	3000 min ⁻¹		1500 min ⁻¹		1000 min ⁻¹	
	Horizontal	Vertical	Horizontal	Vertical	Horizontal	Vertical
WP-DA80M	30	30	30	30	30	30
WP-DA90	30	30	30	30	30	30
WP-DA100	30	30	30	30	30	30
WP-DA112	30	30	30	30	30	30
WP-DA132	30	25	30	30	30	30
WP-DA160	29	19	30	30	30	30
WP-DA180	24	16	30	30	30	30

Approximate shipping specifications

Type	Net weight (kg)	Gross weight (kg)	Cubage (m ³)
WP-DA80M	12	13	0.02
WP-DA90SX	18	19	0.03
WP-DA90LX	20.5	21.5	0.03
WP-DA100LF	29.5	33.5	0.08
WP-DA112M	29.5	33.5	0.05
WP-DA112MX			0.05
WP-DA132SX	57.0	63.0	0.08
WP-DA132MX	60.5	66.5	0.08
WP-DA160M	88	98	0.125
WP-DA160L	92	102	0.125
WP-DA180M	115	130	0.253
WP-DA180L	126	141	0.253

Table includes average motor weight with B3 (foot) mounting type.
The average weight of motor with B5 (flange) mounting type is around 10% higher.

Technical information - aluminium frame:

Mechanical

Axial and radial loads

Maximum permissible external axial and radial loads in Newtons *								
Type	Poles	Horizontal shaft		Vertical shaft				Maximum permissible radial load end of shaft (horizontal mounting)
		Load towards motor	Load away from motor	Shaft up		Shaft down		
				Load towards motor	Load away from motor	Load towards motor	Load away from motor	
WP-DA80	2	339	539	321	565	362	521	774
	4	303	503	283	530	330	583	729
	6	284	484	260	516	316	460	646
WP-DA90	2	444	684	421	716	476	661	915
	4	398	638	366	682	442	606	854
	6	349	589	309	641	401	549	720
WP-DA100	2	768	1088	715	1170	850	1035	1295
	4	690	1010	612	1131	811	932	1202
	6	541	861	463	979	659	783	1141
WP-DA112	2	768	1088	715	1170	850	1035	1295
	4	690	1010	612	1131	811	932	1202
	6	541	861	463	979	659	783	1141
WP-DA132	2	1355	1707	1266	1838	1486	1618	2114
	4	1253	1605	1130	1779	1427	1482	2068
	6	1167	1519	1035	1711	1359	1387	1968
WP-DA160	2	2144	2639	1951	2920	2425	2446	3613
	4	2123	2618	1895	2959	2464	2390	3738
	6	1973	2468	1669	2905	2410	2164	3544
WP-DA180	2	2711	3274	2465	3667	3104	3027	4374
	4	2749	3312	2426	3801	3238	2988	4556
	6	2575	3138	2166	3785	3222	2728	4334

* All figures are based on L_{na} bearing life of 20.000 hours. L_{na} = adjusted L10 life rating taking account of:
- reliability - material improvements - lubrication conditions

Technical information - cast iron frame: Mechanical

Bearings and greasing arrangement

Bearings are pre-packed with a grease type dependant on frame size and re-greasing facility as detailed in table opposite:

Standard and re-greasing facilities			
Type	Re-greasing facility	Polyurea	Lithium complex
80 - 180	Available	EA2, EA7 with temperature range of -40°C to +150°C	Esso Unirex N3 with temperature range of -30°C to +140°C
200 - 355	Standard		

Bearing references and oil seals							
Type		Polarity	Bearings ⁽¹⁾		Oil seals ⁽²⁾		
European	BS		Drive end	Non-drive end	Drive end	Non-drive end	
WP-DF80M	WP-DF80M	All	6204ZZ	6003ZZ	20 x 30 x 7	17 x 28 x 6	
WP-DF90SX/LX	WP-DF90SX/LX	All	6205ZZ	6203ZZ	25 x 35 x 7	17 x 28 x 6	
WP-DF100LF	WP-DF100LF	All	6206ZZ	6205ZZ	30 x 42 x 7	25 x 37 x 7	
WP-DF112M/MX	WP-DF112M/MX	All	6206ZZ	6205ZZ	30 x 42 x 7	25 x 37 x 7	
WP-DF132S/SX/MX	WP-DF132S/SX/MX	All	6208ZZ	6305ZZ	40 x 52 x 7	25 x 37 x 7	
WP-DF160M/L	WP-DF160M/L	All	6309ZZ	6307ZZ	45 x 60 x 8	35 x 47 x 7	
WP-DF180M/L	WP-DF180M/L	All	6310ZZ	6308ZZ	50 x 65 x 8	40 x 52 x 7	
WP-UDF200LX	WP-DF200L/LX	All	6312	6312	60 x 80 x 8 ⁽³⁾	60 x 80 x 8 ⁽³⁾	
WP-UDF225S	WP-DF225S	All	6313	6313	65 x 90 x 10 ⁽⁴⁾	65 x 90 x 10 ⁽⁴⁾	
WP-UDF225M	WP-DF225M	All	6314	6314	70 x 90 x 10 ⁽⁴⁾	70 x 90 x 10 ⁽⁴⁾	
WP-UDF250ME	WP-DF250S	2	6314	6314	70 x 90 x 10 ⁽⁴⁾	70 x 90 x 10 ⁽⁴⁾	
		4up	6316	6316	80 x 110 x 10 ⁽³⁾	80 x 110 x 10 ⁽³⁾	
WP-UDF280SE	WP-DF250M	2	6314	6314	70 x 90 x 10 ⁽⁴⁾	70 x 90 x 10 ⁽⁴⁾	
		4up	6318	6318	90 x 120 x 12 ⁽³⁾	90 x 120 x 12 ⁽³⁾	
WP-UDF280ME	WP-DF280S	2	6314	6314	70 x 90 x 10 ⁽⁴⁾	70 x 90 x 10 ⁽⁴⁾	
		4up	6318	6318	90 x 120 x 12 ⁽³⁾	90 x 120 x 12 ⁽³⁾	
WP-UDF315SE	WP-DF280M	2	6316	6316	70 x 90 x 10 ⁽⁴⁾	70 x 90 x 10 ⁽⁴⁾	
		4up	6319	6319	90 x 120 x 12 ⁽³⁾	90 x 120 x 12 ⁽³⁾	
WP-UDF315ME	WP-DF315S	2	6316	6316	70 x 90 x 10 ⁽⁴⁾	70 x 90 x 10 ⁽⁴⁾	
		4up	6319	6319	90 x 120 x 12 ⁽³⁾	90 x 120 x 12 ⁽³⁾	
WP-UDF315M/L	WP-DF315M/L	2	6316	6316	70 x 90 x 10 ⁽⁴⁾	70 x 90 x 10 ⁽⁴⁾	
		4up	6319	6319	90 x 120 x 12 ⁽³⁾	90 x 120 x 12 ⁽³⁾	
WP-UDF355S/M/L	WP-DF355S/M/L	2	N316	6316	70 x 90 x 10 ⁽⁴⁾	70 x 90 x 10 ⁽⁴⁾	
		4up	N324	6324	115 x 145 x 14 ⁽³⁾	115 x 145 x 14 ⁽³⁾	

(1) - Frame sizes 80 and 90 have bearings with CN clearances, frame sizes 100 to 355 have bearings with C3 clearance 'medium' series
(2) - Size are in mm, and represent bore x diameter x width
Material: (3) - Nitrile rubber (4) - Silicon rubber

Grease life expected at 80°C bearing temperature x 10 ³ hours										
Type		3000 min ⁻¹		1500 min ⁻¹		1000 min ⁻¹		750 min ⁻¹		
European	BS	Horizontal	Vertical	Horizontal	Vertical	Horizontal	Vertical	Horizontal	Vertical	
WP-DF80-112	WP-DF80-112	30.0	30.0	30.0	30.0	30.0	30.0	30.0	30.0	30.0
WP-DF132	WP-DF132	30.0	25.0	30.0	30.0	30.0	30.0	30.0	30.0	30.0
WP-DF160	WP-DF160	29.0	19.0	30.0	30.0	30.0	30.0	30.0	30.0	30.0
WP-DF180	WP-DF180	24.0	16.0	30.0	30.0	30.0	30.0	30.0	30.0	30.0
WP-UDF200LX	WP-DF200L/LX	12.6	8.2	30.0	20.3	30.0	27.8	30.0	30.0	30.0
WP-UDF225S	WP-DF225S	12.6	8.2	30.0	20.3	30.0	27.8	30.0	30.0	30.0
WP-UDF225M	WP-DF225M	11.3	7.4	29.5	19.2	30.0	26.0	30.0	30.0	30.0
WP-UDF250ME	WP-DF250S	11.3	7.4	26.3	17.1	30.0	23.6	30.0	29.3	29.3
WP-UDF280SE	WP-DF250M	11.3	7.4	23.4	15.2	30.0	21.3	30.0	27.8	27.8
WP-UDF280ME	WP-DF280S	11.3	7.4	23.4	15.2	30.0	21.3	30.0	27.8	27.8
WP-UDF315SE	WP-DF280M	9.4	6.1	21.3	13.8	30.0	20.3	30.0	26.0	26.0
WP-UDF315ME	WP-DF315S	9.4	6.1	21.3	13.8	30.0	20.3	30.0	26.0	26.0
WP-UDF315M/L	WP-DF315M/L	9.4	6.1	21.3	13.8	30.0	20.3	30.0	26.0	26.0
WP-UDF355S/M/L ⁽¹⁾	WP-DF355S/M/L	5.0	3.3	8.2	5.3	16.2	10.5	24.5	15.9	15.9
WP-UDF355S/M/L ⁽²⁾	WP-DF355S/M/L	9.4	6.1	13.5	8.8	22.5	14.6	30.0	19.5	19.5

(1) - DE = Drive End
(2) - NDE = Non Drive End

Technical information - cast iron frame: Mechanical

Approximate shipping specifications

European Type	BS Type	Net weight (kg)	Gross weight (kg)	Cubage (m ³)
WP-DF80M	WP-DF80M	15	16.5	0.02
WP-DF90SX/LX	WP-DF90SX/LX	30.5	31.5	0.02
WP-DF100LF	WP-DF100LF	41.8	44.3	0.04
WP-DF112M/MX	WP-DF112M/MX	55.2	58.2	0.06
WP-DF132S/SX	WP-DF132S/SX	78.1	81.1	0.08
WP-DF132M/MX	WP-DF132M/MX	82.6	88.6	0.08
WP-DF160M	WP-DF160M	121	133	0.15
WP-DF160L	WP-DF160L	133	145	0.15
WP-DF180M	WP-DF180M	162	178	0.21
WP-DF180L	WP-DF180L	177.5	193.5	0.21
WP-UDF200LX	WP-DF200L/LX	255	270	0.30
WP-UDF225S	WP-DF225S	320	335	0.37
WP-UDF225M	WP-DF225M	375	390	0.37
WP-UDF250ME	WP-DF250S	420	460	0.63
WP-UDF280SE	WP-DF250M	570	610	0.70
WP-UDF280ME	WP-DF280S	660	721	1.2
WP-UDF315SE	WP-DF280M	800	871	1.2
WP-UDF315ME	WP-DF315S	1000	1095	1.8
WP-UDF315M	WP-DF315M	1100	1195	1.8
WP-UDF315L	WP-DF315L	1300	1395	1.8
WP-UDF355S	WP-DF355S	2000	2120	2.3
WP-UDF355M	WP-DF355M	2300	2420	2.3
WP-UDF355L	WP-DF355L	2500	2620	2.3

Table includes average motor weight with B3 (foot) mounting type.

Axial and radial loads frames 80 - 180

Maximum permissible external axial and radial loads in Newtons*								
Type	Poles	Horizontal shaft		Vertical shaft				Maximum permissible radial load end of shaft (horizontal mounting)
		Load towards motor	Load away from motor	Shaft up		Shaft down		
				Load towards motor	Load away from motor	Load towards motor	Load away from motor	
WP-DF80M	2	339	539	321	565	362	521	774
	4	303	503	283	530	330	583	729
	6	284	484	260	516	316	460	646
WP-DF90SX/LX	2	444	684	421	716	476	661	915
	4	398	638	366	682	442	606	854
	6	349	589	309	641	401	549	720
WP-DF100LF WP-DF112M/MX	2	768	1088	715	1170	850	1035	1295
	4	690	1010	612	1131	811	932	1202
	6	541	861	463	979	659	783	1141
WP-DF132S/SX/M/MX	2	1355	1707	1266	1838	1486	1618	2114
	4	1253	1605	1130	1779	1427	1482	2068
	6	1167	1519	1035	1711	1359	1387	1968
WP-DF160M/L	2	2144	2639	1951	2920	2425	2446	3613
	4	2123	2618	1895	2959	2464	2390	3738
	6	1973	2468	1669	2905	2410	2164	3544
WP-DF180 M/L	2	2711	3274	2465	3667	3104	3027	4374
	4	2749	3312	2426	3801	3238	2988	4556
	6	2575	3138	2166	3785	3222	2728	4334

* All figures are based on Lna bearing life of 20,000 hours. Lna = adjusted L10 life rating taking account of:
- reliability - material improvements - lubrication conditions

Technical information - cast iron frame: Mechanical

Axial and radial loads frames 200 - 355

Maximum permissible external axial thrust and radial loads in Newtons [N]*											
Type	Poles	Horizontal shaft		Vertical shaft				Maximum permissible radial load end of shaft (horizontal mounting)			
		Load towards motor	Load away from motor	Shaft up		Shaft down		Standard ball bearing		Roller bearing	
				Load towards motor	Load away from motor	Load towards motor	Load away from motor	European frame	BS frame	European frame	BS frame
WP-UDF200LX WP-DF200L/LX ¹	2	5435	4775	5005	5361	6021	4345	5125	5125	7541	7541
	4	6058	5398	5531	6121	6781	4871	5588	5588	7541	7541
	6	6055	5395	5457	6215	6875	4797	5536	5536	7541	7541
WP-UDF225S ¹	4	6692	6122	5941	7177	7747	5371	5963	5963	8202	8202
	6	6770	6200	5935	7371	7941	5365	5982	5982	8202	8202
WP-UDF225M WP-DF225M ¹	2	6729	6197	6084	7082	7614	6213	6602	6602	8745	8745
	4	7530	6998	6745	8099	8631	6213	6868	6876	8921	8921
	6	7640	7108	6673	8463	8995	6141	6856	6856	8921	8921
WP-UDF250ME WP-DF250S ¹	2	6640	6108	5837	7209	7741	5305	6262	6262	8921	8921
	4	9012	8418	8030	9794	10388	7436	8163	8163	11342	14166
	6	9391	8797	8311	10311	10905	7717	8477	8477	11342	14166
WP-UDF280SE WP-DF250M ¹	2	6505	5911	5472	7352	7946	4878	5692	5897	8242	8921
	4	10241	9579	8943	11377	12039	8281	9260	9627	17105	14166
	6	10846	10184	9423	12157	12819	8761	9336	10182	17105	14166
WP-UDF280ME WP-DF280S ¹	2	6268	5736	5101	7355	7887	4569	5824	5795	9825	9503
	4	9774	9112	8014	11534	12196	7352	9136	8842	17423	17348
	6	10582	9920	8704	12524	13186	8042	9698	9386	17423	17348
WP-UDF315SE WP-DF280M ¹	2	7443	6849	5921	8957	9551	5327	6804	6804	11342	11342
	4	10305	9965	8299	12719	13059	7959	9443	9443	17414	17414
	6	11190	10850	9050	13810	14150	8710	10042	10042	17414	17414
WP-UDF315ME WP-DF315S ¹	2	7337	6743	5654	9082	9676	5060	6680	6680	11342	11342
	4	10077	9737	7672	13044	13384	7332	9121	9121	17414	20887
	6	10958	10618	8419	14131	14471	8079	9734	9734	17414	20887
WP-UDF315M WP-DF315M ¹	2	7398	6804	5664	9154	9748	5070	6885	6885	11342	11342
	4	10192	9852	8006	12862	13202	7666	9482	9482	17414	20748
	6	11060	10720	8715	13971	14311	8375	10066	10066	17414	20748
WP-UDF315L WP-DF315L ¹	2	7055	6461	5050	9164	9758	4456	6603	6606	11342	11342
	4	10008	9668	7501	13123	13463	7161	9207	9207	17414	20748
	6	10872	10532	8207	14229	14569	7867	9801	9801	17414	20748
WP-UDF355S WP-DF355S ¹	2	6118	5524	3136	9692	10286	2542	-	-	12627	12627
	4	12994	11454	8799	17389	18929	7259	-	-	27533	27533
	6	14038	12498	9387	19143	20683	7847	-	-	27533	27533
WP-UDF355M WP-DF355M ¹	2	5779	5185	2326	10050	10644	1732	-	-	12627	12627
	4	12528	10988	7511	18055	19595	5971	-	-	27533	27533
	6	13148	11608	7523	19533	21073	5983	-	-	27533	27533
WP-UDF355L WP-DF355L ¹	2	5595	5001	1734	10396	10990	1140	-	-	12627	12627
	4	12343	10803	7038	18282	19822	5498	-	-	27533	27533
	6	12936	11396	6980	19794	21334	5440	-	-	27533	27533

* All figures are based on L_{na} bearing life of 20.000 hours. L_{na} = adjusted L10 life rating taking account of:-
- reliability - material improvements - lubrication conditions

1 - BS frame reference

Technical information: Electrical

Typical speed/current curve

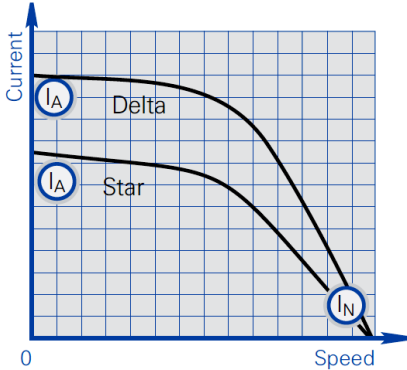

Frame size 80 - 180

Typical speed/current curve

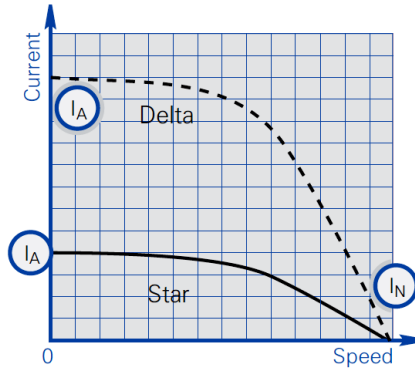

Frame size 200 - 355

Typical speed/torque curve

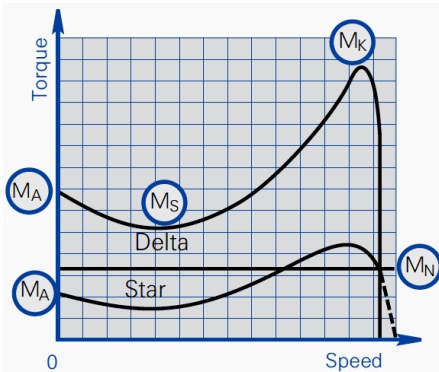

Frame size 80 - 180

Typical speed/torque curve

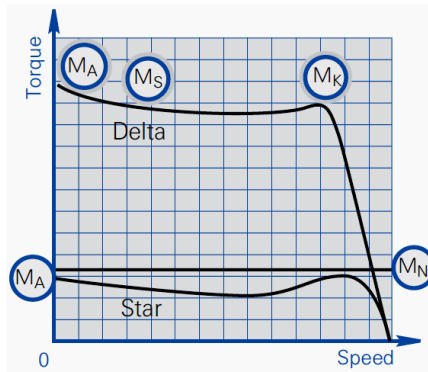

Frame size 200 - 355

Description

- I_A Starting current
- I_N Full load current
- M_A Starting torque or locked rotor torque
- M_S Pull up torque or run up torque
- M_k Pull out torque or breakdown torque
- M_N Full load torque

Torque/speed curves for specific motors can be supplied on request.

Performance figures are subject to IEC tolerance. Performance figures are based on a 400 volt winding.

To calculate I_N on special voltages, multiply the I_N at 400 volts by the following factors:

Voltage	220	346	365	420	440	500	550
Factor	1.82	1.16	1.1	0.95	0.91	0.80	0.73

Notes

During the run up period in Star, there must be an adequate excess of motor torque over the load torque. The change to delta must not occur until the motor is near the operating speed.

Motors are wound for either 230/400 volts or 400/690 volts.

Connection diagrams

Star Delta

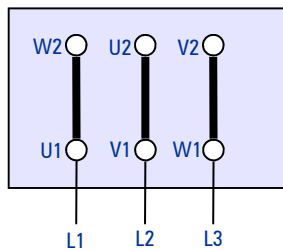

D.O.L.
 Δ

Dual Voltage

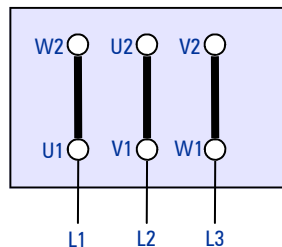

Δ

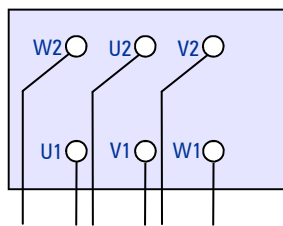

Motors output power => 4kW

Y/ Δ

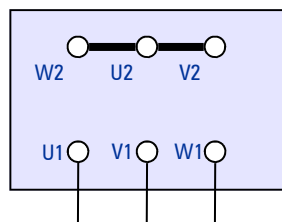

Y

Thermistors

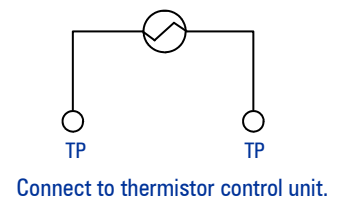

Heaters

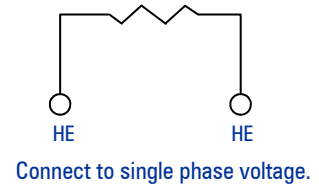

Useful information

Motor Duty Types

IEC 60034-1 defines various duty types that describe how the load and motor output varies with time. The motor must undergo a load test without exceeding the temperature limits laid down in the specification.

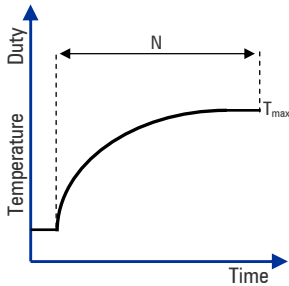

S1 continuous duty

Operation at a constant load and long enough for thermal equilibrium to be reached.

N - Operation Rated Condition
T_{max} - Maximum Temperature Rise

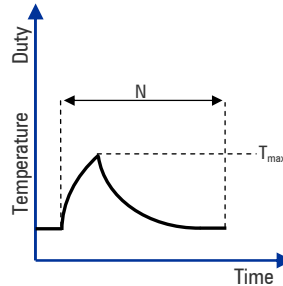

S2 short time duty

Operation at constant load for a given time that is shorter than the time needed to reach thermal equilibrium, followed by a rest and de-energised period. The de-energisation period should be long enough to allow the motor to reach a temperature that does not deviate from the temperature of the cooling medium by 2K.

N - Operation Rated Condition
T_{max} - Maximum Temperature Rise

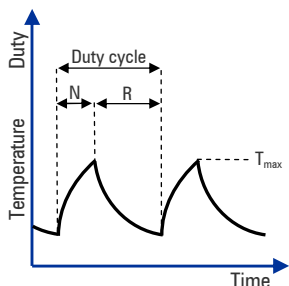

S3 intermittent duty

A sequence of identical duty cycles, where each cycle is in two parts, one at constant load and the other at rest and de-energised. In this type of duty the starting current has no significant effect on the temperature rise. The duty cycle is too short for thermal equilibrium to be reached.

N - Operation Rated Condition
R - At rest / De-energised
T_{max} - Maximum Temperature Rise

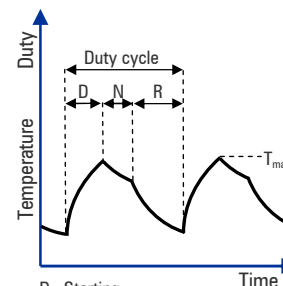

S4 intermittent duty with starting

A sequence of individual duty cycles, where each cycle consists of a start that is sufficiently long to have a significant effect on the motor temperature, a period of constant load and a period at rest and de-energised. In this type of duty the starting current is insignificant on the temperature rise. The duty cycles are too short for thermal equilibrium to be reached.

D - Starting
N - Operation Rated Condition
R - At rest / De-energised
T_{max} - Maximum Temperature Rise

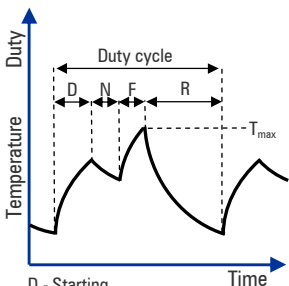

S5 intermittent duty with electrical braking

A sequence of identical duty cycles, where each cycle consists of a start, a period at constant load followed by rapid electrical braking, and a rest and de-energised period. The duty cycle is too short for thermal equilibrium to be reached.

D - Starting
N - Operation Rated Condition
F - Electrical Braking
R - At rest / De-energised
T_{max} - Maximum Temperature Rise

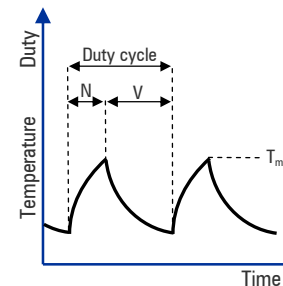

S6 continuous operation periodic duty

A sequence of identical duty cycles, where each cycle is in two parts, one at constant load and the other at no load, no rest and no de-energised period. The duty cycles are too short for thermal equilibrium conditions to be reached.

N - Operation Rated Condition
V - Operation at No Load
T_{max} - Maximum Temperature Rise

IP Rating

1st Digit	Protection from solid objects	2nd Digit	Protection from moisture
0	No special protection	0	No special protection
1	Protection from a large part of the body such as a hand, from solid objects greater than 50mm in diameter.	1	Protection from dripping water.
2	Protection against fingers or other object not greater than 80mm in length and 12mm in diameter.	2	Protection from vertically dripping water.
3	Protection from entry by tools, wires, etc., with a diameter of thickness greater than 2.5mm.	3	Protection from water sprayed at an angle up to 60° from the vertical .
4	Protection from entry by solid objects with a diameter or thickness greater than 1.0mm	4	Protection from water splashed from any direction.
5	Protection from the amount of dust that would interfere with the operation of the equipment.	5	Protection from water projected from a nozzle from any direction.
6	Dust tight.	6	Protection against heavy seas, or water from temporary flooding.
		7	Protection against immersion.
		8	Protection against complete, continuous submersion in water.

IEC/EN 60034-5 and EN 60529 outlines an international classification system for the sealing effectiveness of enclosures of electrical equipment against the intrusion into the equipment of foreign bodies (i.e. tools, dust, fingers) and moisture. This classification system utilizes the letters "IP" ("Ingress Protection") followed by two or three digits. (A third digit is sometimes used. An "X" is used for one of the digits if there is only one class of protection; i.e. IPX4 which addresses moisture resistance only.)

Degrees of Protection - First Digit

The first digit of the IP code indicates the degree that persons are protected against contact with moving parts (other than smooth rotating shafts, etc.) and the degree that equipment is protected against solid foreign bodies intruding into an enclosure.

Degrees of Protection - Second Digit

The second digit indicates the degree of protection of the equipment inside the enclosure against the harmful entry of various forms of moisture (e.g. dripping, spraying, submersion, etc.)

Worldwide sales and service network

AUSTRIA

ATB Motorenwerke GmbH
G.-Bauknecht-Str. 1
8724 Spielberg
T: +43 3577 757-323
F: +43 3577 757-182
info@atb-motors.com
ATB Technologies GmbH
Millenium Park 11
6890 Lustenau
T: +43 5577 9010-0
F: +43 5577 9010-110
info@atb-motors.com

ASIA

ATB Motorentechnik GmbH
141 Market Street,
07-01 International Factors
Building
Singapore 048944
T: +65 63721174
F: +65 62253524
dennis.tan@atbs.com.sg

BAHREIN

ATB Austria Antriebstechnik Aktiengesellschaft,
Rep. Office Bahrain
Almoayyed Tower
21st Floor c/o Regus
Seef District, Manama
Kingdom of Bahrain
T: +973 175 68 160
F: +973 175 67 901

BENELUX

ATB BeNeLux B.V.
Tasveld 14
8271 RW IJsselmuiden
T: +31 38 443 2110
F: +31 38 443 2111
verkoop@nl.atb-motors.com

GERMANY

ATB Antriebstechnik GmbH
Silcherstraße 74
73642 Welzheim
T: +49 7182 14-535
F: +49 7182 14 590
info@de.atb-motors.com

ATB Motorentechnik GmbH
Helgoländer Damm 75
26954 Nordenham
T: +49 4731 365-0
F: +49 4731 365-159
nordenham@de.atb-motors.com

Schorch Elektrische Maschinen
und Antriebe GmbH
Breite Straße 131
41238 Mönchengladbach
T: +49 2166 925-0
T: +49 2166 925-100
mail@schorch.de

POLAND

Fabryka Silnikow Elektrycznych Tamel S.A. ul.
Elektryczna 6
33 100 Tarnow
T: +48 14 632 11 00
F: +48 14 632 11 02
Office.tamel@tamel.pl

RUSSIA

ATB Rus 000
Petrovka ul. 27
107031 Moscow
T: +7 495 95 66 326
vyacheslav.mikheyev@a-tecindustries.com

SERBIA

ATB Sever a.d.
Magnetna polja 6
24000 Subotica
T: +381 24 548 111
sever@rs.atb-motors.com
ATB FOD d.o.o.
Dorda Vajferta 16
19210 Bor
T: +381 30 423 147
fod@fod.co.rs

SWITZERLAND

ATB Schweiz AG
Industriestraße 28
5600 Lenzburg
T: +41 62 885 70-10
info@ch.atb-motors.com

UK & IRELAND

ATB Laurence Scott Ltd.
PO Box 25 Hardy Road, Norwich NR1 1JD
Norfolk
T: +44 1603 628 333
hvm.sales@laurence-scott.com

ATB Morley Limited
Bradford Road
Leeds LS28 6QA
West Yorkshire
T: +44 113 257 1734
sales@uk.atb-motors.com

Brook Crompton UK
St. Thomas Road, Huddersfield HD1 3LJ
West Yorkshire
T: +44 1484557200
F: +44 1484557201
csc@brookcrompton.com

CANADA

Brook Crompton
North America
264 Attwell Drive
M9W 5B2 Toronto, Ontario
T: +1 416 675-3844
ramzi.mallouk@brookcromptonna.com



**BROOK
CROMPTON**

rh_09/11 ©Copyright 2009. Tamel. All rights reserved